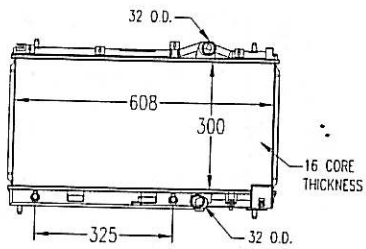
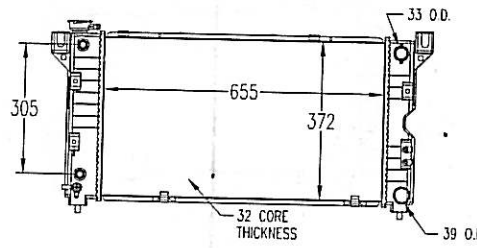
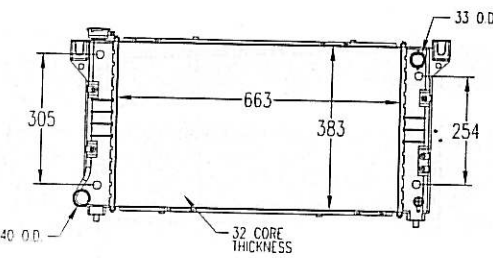
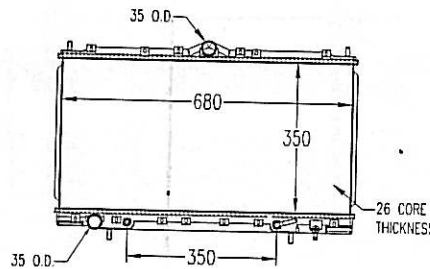
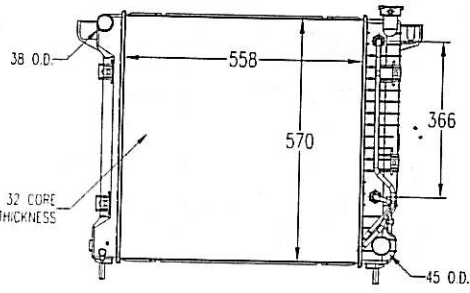
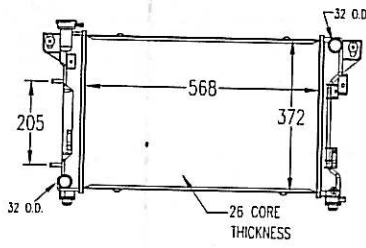
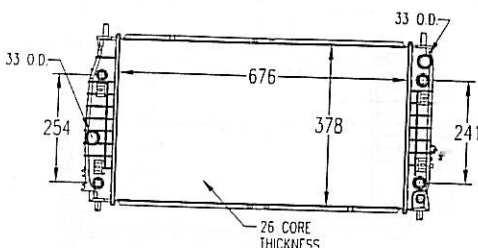
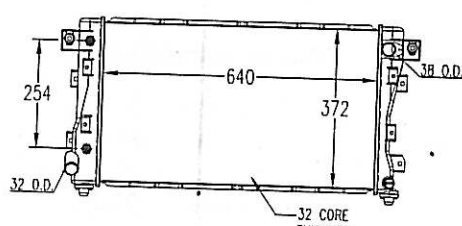
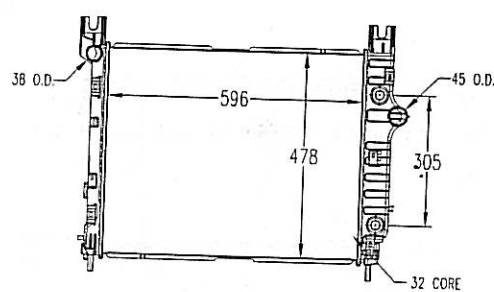
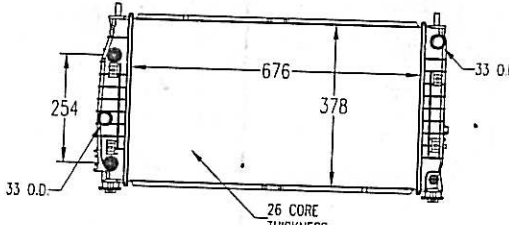
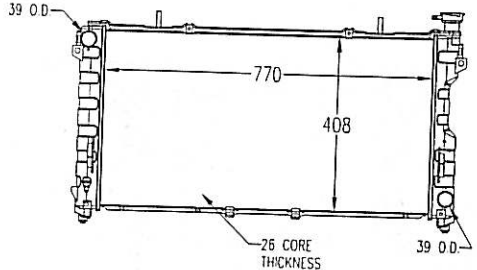
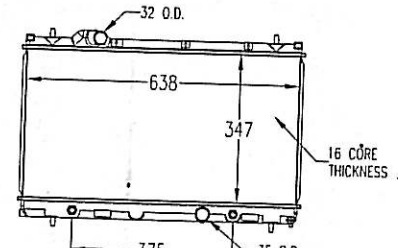

CHRYSLER

<p>95-99 Neon LT0235 DPI:1548</p>  <p>Core Size: 11-13/16×23-15/16×5/8</p> <p>Inlet Header: 24-11/16×1-9/16 Outlet Header: 24-11/16×1-7/8 Tran Oil Cooler: 12(Concentric)</p> <p>Inlet Conn: 1-1/4 Outlet Conn: 1-1/4 Eng Oil Cooler: NONE</p> <p>OEM: 4495947 / 52462630 NISSENS: 609941</p>	<p>96-00 Caravan/Grand Caravan LT0326 DPI:1850</p>  <p>Core Size: 25-13/16×14-5/8×1-1/4</p> <p>Inlet Header: 15-5/8×2-5/16 Outlet Header: 15-5/8×2-5/16 Tran Oil Cooler: 12(Concentric)</p> <p>Inlet Conn: 1-5/16 Outlet Conn: 1-9/16 Eng Oil Cooler: NONE</p> <p>OEM: 4682587AB / 4682976AB</p>
<p>96-00 Caravan/Grand Caravan LT0330 DPI:1862</p>  <p>Core Size: 26-1/8×15-1/16×1-1/4</p> <p>Inlet Header: 15-5/8×2-5/16 Outlet Header: 15-5/8×2-5/16 Tran Oil Cooler: 12(Concentric)</p> <p>Inlet Conn: 1-5/16 Outlet Conn: 1-9/16 Eng Oil Cooler: 10(Concentric)</p> <p>OEM: 465A587 / 4682587</p>	<p>95-00 Avenger / Sebring LT0337 DPI:1892</p>  <p>Core Size: 13-3/4×26-3/4×1</p> <p>Inlet Header: 27-1/2×1-7/8 Outlet Header: 27-1/2×1-7/8 Tran Oil Cooler: 13-3/4(Concentric)</p> <p>Inlet Conn: 1-3/8 Outlet Conn: 1-3/8 Eng Oil Cooler: NONE</p> <p>OEM: MR127912 / MR385508</p>
<p>97-99 Dakota/98-99 Durango LT0342 DPI:1905</p>  <p>Core Size: 21-15/16×22-1/2×1-1/4</p> <p>Inlet Header: 2-5/8×23-3/16 Outlet Header: 2-5/8×23-3/16 Tran Oil Cooler: 14-3/8(Concentric)</p> <p>Inlet Conn: 1-1/2 Outlet Conn: 1-3/4 Eng Oil Cooler: NONE</p> <p>OEM: 52028775 / 52028775AA NISSENS: 60998</p>	<p>91- Imperial LT0101 DPI:1109</p>  <p>Core Size: 22-3/8×14-5/8×1</p> <p>Inlet Header: 15-9/16×2-1/8 Outlet Header: 15-9/16×2-1/8 Tran Oil Cooler: NONE</p> <p>Inlet Conn: 1-1/4 Outlet Conn: 1-1/4 Eng Oil Cooler: 8(Concentric)</p> <p>OEM: 4401973 / 4401974</p>

CHRYSLER

<p>98- 300M LT0411 DPI:2184</p>  <p>Core Size: 26-5/8×14-7/8×1</p> <p>Inlet Header: 15-9/16×1-15/16 Outlet Header: 15-9/16×1-15/16 Tran Oil Cooler: 10(4-Plate)</p> <p>Inlet Conn: 1-5/16 Outlet Conn: 1-5/16 Eng Oil Cooler: 9-1/2(Concentric)</p> <p>OEM: 4758288AB / 5010359</p>	<p>93- Concorde LT0167 DPI:1390</p>  <p>Core Size: 25-3/16×14-5/8×1-1/4</p> <p>Inlet Header: 15-5/8×2-3/8 Outlet Header: 15-5/8×2-3/8 Tran Oil Cooler: NONE</p> <p>Inlet Conn: 1-1/4 Outlet Conn: 1-1/4 Eng Oil Cooler: 10(Concentric)</p> <p>OEM: 4592048 / 4592050</p>
<p>00-03 Durango / 00-04 Dakota LT0457 DPI:2294</p>  <p>Core Size: 23-7/16×18-13/16×1-1/4</p> <p>Inlet Header: 19-5/8×2-3/8 Outlet Header: 19-5/8×2-3/8 Tran Oil Cooler: 12(5-Plate)</p> <p>Inlet Conn: 1-1/2 Outlet Conn: 1-3/4 Eng Oil Cooler: NONE</p> <p>OEM: 52028818AB / 52028818AD</p>	<p>98-04 Intrepid / Concorde LT0410 DPI:2183</p>  <p>Core Size: 26-5/8×14-7/8×1</p> <p>Inlet Header: 15-9/16×1-15/16 Outlet Header: 15-9/16×1-15/16 Tran Oil Cooler: 10(4-Plate)</p> <p>Inlet Conn: 1-5/16 Outlet Conn: 1-5/16 Eng Oil Cooler: NONE</p> <p>OEM: 4758288 / 5010359AB</p>
<p>01-04 Caravan/Grand Caravan LT0473 DPI:2311</p>  <p>Core Size: 30-5/16×16-1/16×1</p> <p>Inlet Header: 17-1/16×2-3/8 Outlet Header: 17-1/16×2-3/8 Tran Oil Cooler: NONE</p> <p>Inlet Conn: 1-1/2 Outlet Conn: 1-1/2 Eng Oil Cooler: NONE</p> <p>OEM: 4809168 / 4809168AD</p>	<p>00-04 Neon LT0510 DPI:2362</p>  <p>Core Size: 13-11/16×25-1/8×5/8</p> <p>Inlet Header: 25-15/16×1-7/8 Outlet Header: 25-15/16×1-7/8 Tran Oil Cooler: 14-3/4(Concentric)</p> <p>Inlet Conn: 1-1/4 Outlet Conn: 1-3/8 Eng Oil Cooler: NONE</p> <p>OEM: 5019213AA / 5019214AA</p>

CHRYSLER

LT0579

DPI:2479

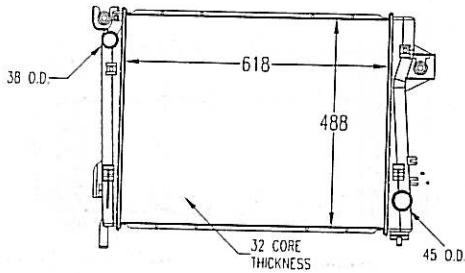

Core Size: 24-5/16x19-3/16x1-1/4

Inlet Header: 20-3/16x2-3/8
 Outlet Header: 20-3/16x2-3/8
 Tran Oil Cooler: NONE
 Inlet Conn: 1-1/2
 Outlet Conn: 1-3/4
 Eng Oil Cooler: NONE

OEM: 52030191AB / 2035001103

02-06 Liberty

LT0581

DPI:2481

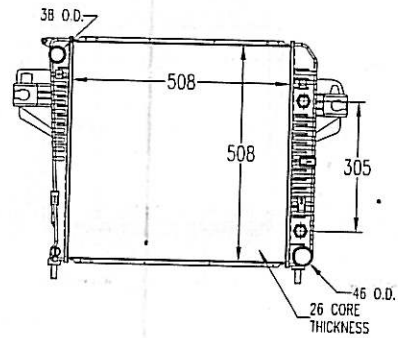

Core Size: 20x20x1

Inlet Header: 20-13/16x2-3/8
 Outlet Header: 20-13/16x2-3/8
 Tran Oil Cooler: 12(5-Plate)
 Inlet Conn: 1-1/2
 Outlet Conn: 1-13/16
 Eng Oil Cooler: NONE

OEM: 52079728AB / 52079729AB

LT0582

DPI:2482

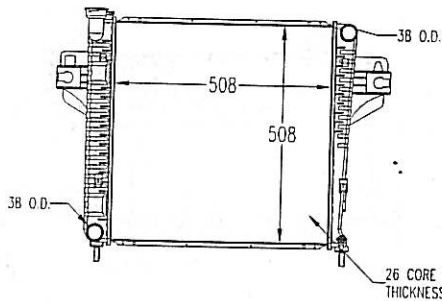

Core Size: 20x20x1

Inlet Header: 20-13/16x2-3/8
 Outlet Header: 20-13/16x2-3/8
 Tran Oil Cooler: NONE
 Inlet Conn: 1-1/2
 Outlet Conn: 1-1/2
 Eng Oil Cooler: NONE

OEM: 52079731AC / 52080123AA

LT0580

DPI:2480

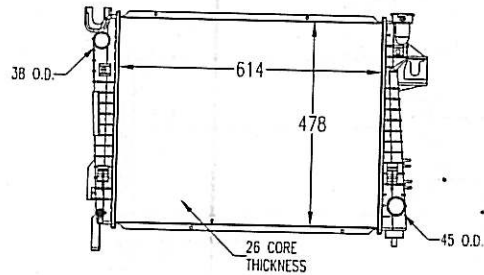

Core Size: 24-3/16x18-13/16x1

Inlet Header: 19-5/8x3
 Outlet Header: 19-5/8x3
 Tran Oil Cooler: NONE
 Inlet Conn: 1-1/2
 Outlet Conn: 1-3/4
 Eng Oil Cooler: NONE

OEM: 52028830AE / 52028830AF

LT0478

DPI:2323

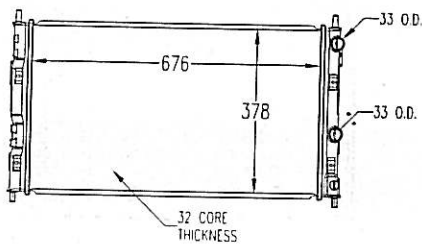

Core Size: 26-5/8x14-7/8x1-1/4

Inlet Header: 15-5/8x2-3/8
 Outlet Header: 15-5/8x2-3/8
 Tran Oil Cooler: NONE
 Inlet Conn: 1-1/4
 Outlet Conn: 1-1/4
 Eng Oil Cooler: NONE

OEM: 4773642 / 5017619

2008-1-401-04 Caravan/Grand Caravan

LT0474

DPI:2312

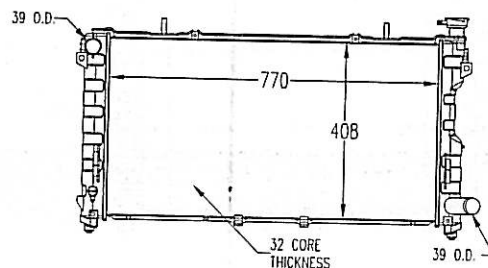

Core Size: 30-5/16x16-1/16x1-1/4

Inlet Header: 17-1/16x2-3/8
 Outlet Header: 17-1/16x2-3/8
 Tran Oil Cooler: NONE
 Inlet Conn: 1-1/2
 Outlet Conn: 1-1/2
 Eng Oil Cooler: NONE

OEM: 4677494AA / 4809238

CHRYSLER

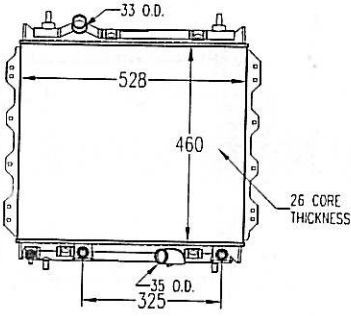
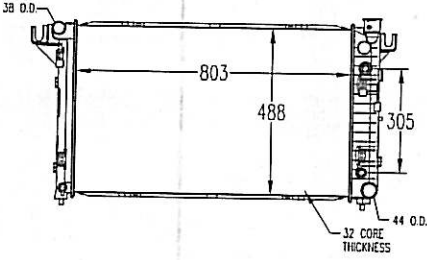
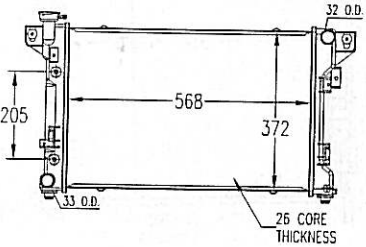
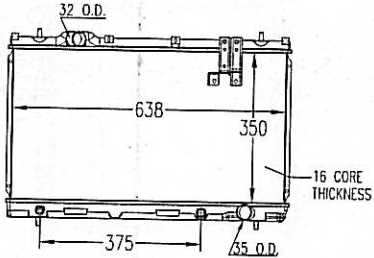
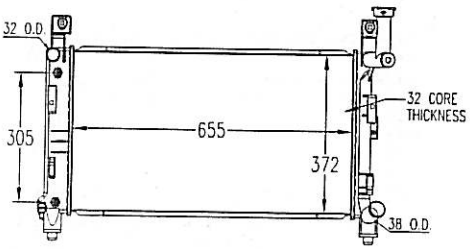
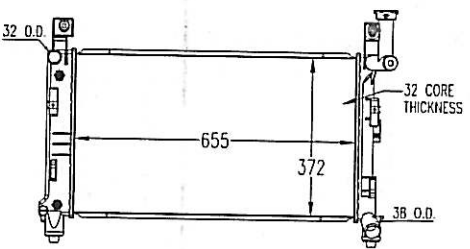
01-02 PT Cruiser	98-02 RAM												
LT0459	LT0454												
<p style="text-align: right;">DPI:2298</p>  <p style="text-align: center;">Core Size: 18-1/8×20-3/4×1</p> <table border="0" style="width: 100%;"> <tr> <td>Inlet Header: 20-3/4×1-19/20</td> <td>Inlet Conn: 1-3/8</td> </tr> <tr> <td>Outlet Header: 20-3/4×1-19/20</td> <td>Outlet Conn: 1-3/8</td> </tr> <tr> <td>Tran Oil Cooler: NONE</td> <td>Eng Oil Cooler: 12-13/16(Concentric)</td> </tr> </table>	Inlet Header: 20-3/4×1-19/20	Inlet Conn: 1-3/8	Outlet Header: 20-3/4×1-19/20	Outlet Conn: 1-3/8	Tran Oil Cooler: NONE	Eng Oil Cooler: 12-13/16(Concentric)	<p style="text-align: right;">DPI:2291</p>  <p style="text-align: center;">Core Size: 31-5/8×19-3/16×1-1/4</p> <table border="0" style="width: 100%;"> <tr> <td>Inlet Header: 20-3/16×2-3/8</td> <td>Inlet Conn: 1-1/2</td> </tr> <tr> <td>Outlet Header: 20-3/16×2-3/8</td> <td>Outlet Conn: 1-3/4</td> </tr> <tr> <td>Tran Oil Cooler: NONE</td> <td>Eng Oil Cooler: 12(6-Plate)</td> </tr> </table>	Inlet Header: 20-3/16×2-3/8	Inlet Conn: 1-1/2	Outlet Header: 20-3/16×2-3/8	Outlet Conn: 1-3/4	Tran Oil Cooler: NONE	Eng Oil Cooler: 12(6-Plate)
Inlet Header: 20-3/4×1-19/20	Inlet Conn: 1-3/8												
Outlet Header: 20-3/4×1-19/20	Outlet Conn: 1-3/8												
Tran Oil Cooler: NONE	Eng Oil Cooler: 12-13/16(Concentric)												
Inlet Header: 20-3/16×2-3/8	Inlet Conn: 1-1/2												
Outlet Header: 20-3/16×2-3/8	Outlet Conn: 1-3/4												
Tran Oil Cooler: NONE	Eng Oil Cooler: 12(6-Plate)												
OEM: 5017101 / 501740AA	OEM: 52006491AC / 52029176AA												
91- Shadow	00-04 Neon												
LT0100	LT0511												
<p style="text-align: right;">DPI:1108</p>  <p style="text-align: center;">Core Size: 22-3/8×14-5/8×1</p> <table border="0" style="width: 100%;"> <tr> <td>Inlet Header: 15-9/16×2-1/8</td> <td>Inlet Conn: 1-1/4</td> </tr> <tr> <td>Outlet Header: 15-9/16×2-1/8</td> <td>Outlet Conn: 1-1/4</td> </tr> <tr> <td>Tran Oil Cooler: NONE</td> <td>Eng Oil Cooler: 8(Concentric)</td> </tr> </table>	Inlet Header: 15-9/16×2-1/8	Inlet Conn: 1-1/4	Outlet Header: 15-9/16×2-1/8	Outlet Conn: 1-1/4	Tran Oil Cooler: NONE	Eng Oil Cooler: 8(Concentric)	<p style="text-align: right;">DPI:2363</p>  <p style="text-align: center;">Core Size: 13-3/4×25-1/8×5/8</p> <table border="0" style="width: 100%;"> <tr> <td>Inlet Header: 25-15/16×2-1/2</td> <td>Inlet Conn: 1-1/4</td> </tr> <tr> <td>Outlet Header: 25-15/16×2-1/2</td> <td>Outlet Conn: 1-3/8</td> </tr> <tr> <td>Tran Oil Cooler: NONE</td> <td>Eng Oil Cooler: 14-3/4(Concentric)</td> </tr> </table>	Inlet Header: 25-15/16×2-1/2	Inlet Conn: 1-1/4	Outlet Header: 25-15/16×2-1/2	Outlet Conn: 1-3/8	Tran Oil Cooler: NONE	Eng Oil Cooler: 14-3/4(Concentric)
Inlet Header: 15-9/16×2-1/8	Inlet Conn: 1-1/4												
Outlet Header: 15-9/16×2-1/8	Outlet Conn: 1-1/4												
Tran Oil Cooler: NONE	Eng Oil Cooler: 8(Concentric)												
Inlet Header: 25-15/16×2-1/2	Inlet Conn: 1-1/4												
Outlet Header: 25-15/16×2-1/2	Outlet Conn: 1-3/8												
Tran Oil Cooler: NONE	Eng Oil Cooler: 14-3/4(Concentric)												
OEM: 4401036 / 4401037 NISSENS: 69219	OEM: 5014580AA / 5014581AA												
93-95 Caravan/Grand Caravan	93-95 Caravan/Grand Caravan												
LT0166	LT0169												
<p style="text-align: right;">DPI:1388</p>  <p style="text-align: center;">Core Size: 25-9/16×14-5/8×1-1/4</p> <table border="0" style="width: 100%;"> <tr> <td>Inlet Header: 15-5/8×2-3/8</td> <td>Inlet Conn: 1-1/4</td> </tr> <tr> <td>Outlet Header: 15-5/8×2-3/8</td> <td>Outlet Conn: 1-1/2</td> </tr> <tr> <td>Tran Oil Cooler: 12(Concentric)</td> <td>Eng Oil Cooler: NONE</td> </tr> </table>	Inlet Header: 15-5/8×2-3/8	Inlet Conn: 1-1/4	Outlet Header: 15-5/8×2-3/8	Outlet Conn: 1-1/2	Tran Oil Cooler: 12(Concentric)	Eng Oil Cooler: NONE	<p style="text-align: right;">DPI:1392</p>  <p style="text-align: center;">Core Size: 25-9/16×14-5/8×1-1/4</p> <table border="0" style="width: 100%;"> <tr> <td>Inlet Header: 15-5/8×2-3/8</td> <td>Inlet Conn: 1-1/4</td> </tr> <tr> <td>Outlet Header: 15-5/8×2-3/8</td> <td>Outlet Conn: 1-1/2</td> </tr> <tr> <td>Tran Oil Cooler: 12(Concentric)</td> <td>Eng Oil Cooler: NONE</td> </tr> </table>	Inlet Header: 15-5/8×2-3/8	Inlet Conn: 1-1/4	Outlet Header: 15-5/8×2-3/8	Outlet Conn: 1-1/2	Tran Oil Cooler: 12(Concentric)	Eng Oil Cooler: NONE
Inlet Header: 15-5/8×2-3/8	Inlet Conn: 1-1/4												
Outlet Header: 15-5/8×2-3/8	Outlet Conn: 1-1/2												
Tran Oil Cooler: 12(Concentric)	Eng Oil Cooler: NONE												
Inlet Header: 15-5/8×2-3/8	Inlet Conn: 1-1/4												
Outlet Header: 15-5/8×2-3/8	Outlet Conn: 1-1/2												
Tran Oil Cooler: 12(Concentric)	Eng Oil Cooler: NONE												
OEM: 4644266 / 4644361AB	OEM: 4644045 / 4644345												

CHRYSLER

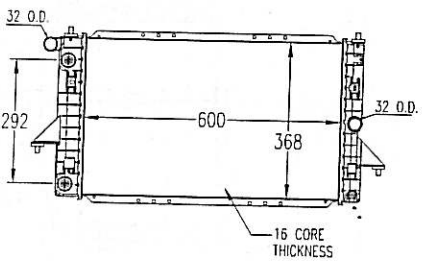
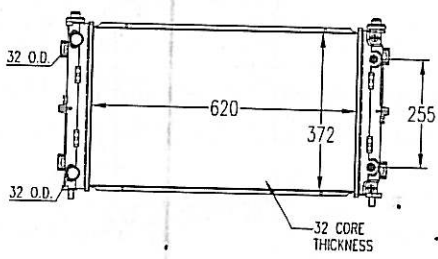
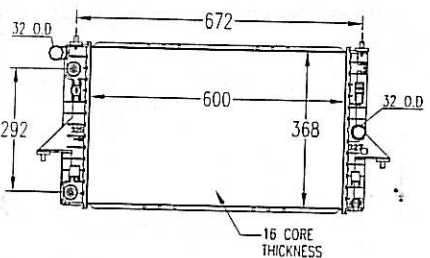
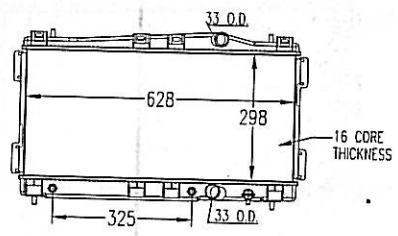
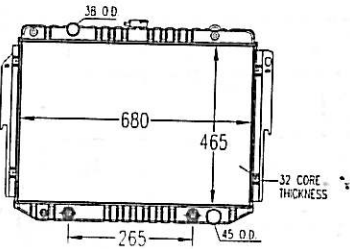
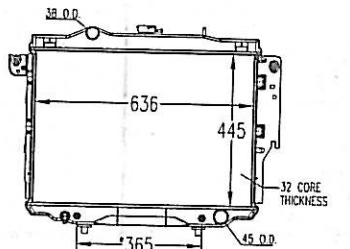
<p>91-93 S Series LT0176 DPI:1398</p>  <p>Core Size: 23-5/8x14-1/2x5/8</p> <p>Inlet Header: 15-3/8x2-1/4 Outlet Header: 15-3/8x2-1/4 Tran Oil Cooler: 11-1/2(Concentric)</p> <p>Inlet Conn: 1-1/4 Outlet Conn: 1-1/4 Eng Oil Cooler: NONE</p> <p>OEM: 21030615 / 21030626</p>	<p>95- Stratus LT0275 DPI:1702</p>  <p>Core Size: 24-7/16x14-5/8x1-1/4</p> <p>Inlet Header: 15-5/8x2-3/8 Outlet Header: 15-5/8x2-3/8 Tran Oil Cooler: NONE</p> <p>Inlet Conn: 1-1/4 Outlet Conn: 1-1/4 Eng Oil Cooler: 10(Concentric)</p> <p>OEM: 4596399AA / 4596400AA</p>
<p>94-02 S Series LT0412 DPI:2191</p>  <p>Core Size: 23-5/8x14-1/2x5/8</p> <p>Inlet Header: 15-1/2x2-1/4 Outlet Header: 15-1/2x2-1/4 Tran Oil Cooler: 11-1/2(Concentric)</p> <p>Inlet Conn: 1-1/4 Outlet Conn: 1-1/4 Eng Oil Cooler: NONE</p> <p>OEM: 52474360 / 52476876 NISSENS: 689011</p>	<p>95-99 Neon LT0415 DPI:2196</p>  <p>Core Size: 11-3/4x24-3/4x5/8</p> <p>Inlet Header: 25-9/16x2 Outlet Header: 25-9/16x2 Tran Oil Cooler: NONE</p> <p>Inlet Conn: 1-5/16 Outlet Conn: 1-5/16 Eng Oil Cooler: 12-3/4(Concentric)</p> <p>OEM: 4546900 / 4569002</p>
<p>94-03 B Series/Ram Vans LT0281 DPI:1707</p>  <p>Core Size: 18-5/16x26-3/4x1-1/4</p> <p>Inlet Header: 27-1/6x2 Outlet Header: 27-1/6x2 Tran Oil Cooler: NONE</p> <p>Inlet Conn: 1-1/2 Outlet Conn: 1-3/4 Eng Oil Cooler: 14-3/8(Concentric)</p> <p>OEM: 52028627AB / 52029116</p>	<p>94-96 Dakota LT0283 DPI:1709</p>  <p>Core Size: 25x17-1/2x1-1/4</p> <p>Inlet Header: 26-1/6x2-1/2 Outlet Header: 26-1/6x2-1/2 Tran Oil Cooler: NONE</p> <p>Inlet Conn: 1-1/2 Outlet Conn: 1-3/4 Eng Oil Cooler: 14-3/8(Concentric)</p> <p>OEM: 52029112 / 52030113</p>

CHRYSLER

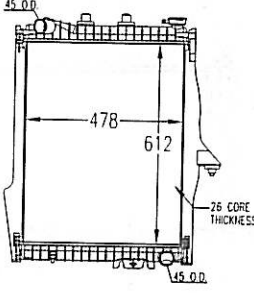
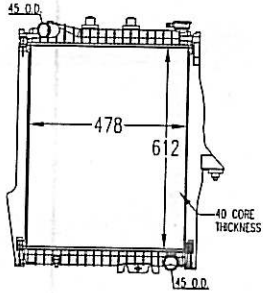
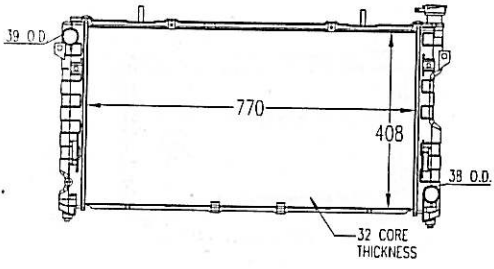
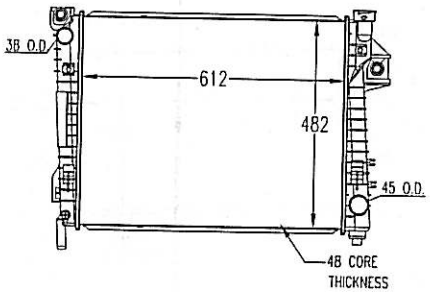
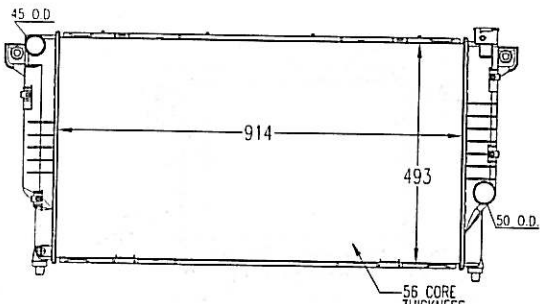
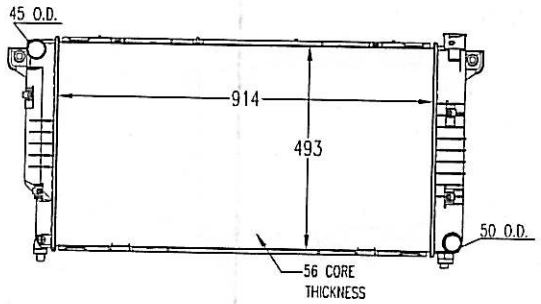
<p>LT0624 DPI: 2738</p>  <p>Core Size: 24x18-5/6x1</p> <p>Inlet Header: 19-11/16x2-1/2 Outlet Header: 19-11/16x2-1/2 Tran Oil Cooler: NONE</p> <p>Inlet Conn: 1-3/4 Outlet Conn: 1-3/4 Eng Oil Cooler: NONE</p> <p>OEM: 52029043AB</p>	<p>LT0625 DPI: 2739</p>  <p>Core Size: 24x18-5/6x1-9/16</p> <p>Inlet Header: 19-11/16x2-1/2 Outlet Header: 19-11/16x2-1/2 Tran Oil Cooler: NONE</p> <p>Inlet Conn: 1-3/4 Outlet Conn: 1-3/4 Eng Oil Cooler: NONE</p> <p>OEM: 52029044AB</p>
<p>LT0632 DPI: 2795</p>  <p>Core Size: 30-5/16x16x1-1/4</p> <p>Inlet Header: 17-1/8x2 Outlet Header: 17-1/8x2 Tran Oil Cooler: NONE</p> <p>Inlet Conn: 1-1/2 Outlet Conn: 1-1/2 Eng Oil Cooler: NONE</p> <p>OEM: 4677523AA</p>	<p>LT0633 DPI: 2813</p>  <p>Core Size: 24x19x1-8/9</p> <p>Inlet Header: 19-5/8x3 Outlet Header: 19-5/8x3 Tran Oil Cooler: NONE</p> <p>Inlet Conn: 1-1/2 Outlet Conn: 1-3/4 Eng Oil Cooler: NONE</p> <p>OEM: 55056481AB</p>
<p>94-01 RAM LT0239 DPI: 1553</p>  <p>Core Size: 36x19-7/16x2-1/4</p> <p>Inlet Header: 20-1/8x3-5/16 Outlet Header: 20-1/8x3-5/16 Tran Oil Cooler: NONE</p> <p>Inlet Conn: 1-3/4 Outlet Conn: 2 Eng Oil Cooler: NONE</p> <p>OEM: 52006479 / 52030191</p>	<p>94-01 RAM LT0240 DPI: 1554</p>  <p>Core Size: 36x19-3/8x2-3/16</p> <p>Inlet Header: 20-1/8x3-5/16 Outlet Header: 20-1/8x3-5/16 Tran Oil Cooler: NONE</p> <p>Inlet Conn: 1-3/4 Outlet Conn: 2 Eng Oil Cooler: NONE</p> <p>OEM: 52030106 / 52006478</p>

CHRYSLER

95- Stratus

LT0274

DPI:1701

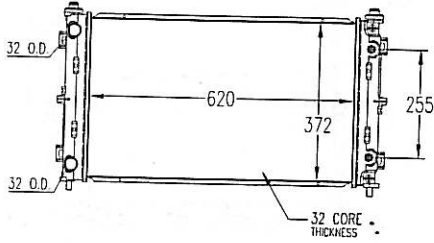

Core Size: 24-7/16x14-5/8x1-1/4

Inlet Header: 15-5/8x2-3/8
 Outlet Header: 15-5/8x2-3/8
 Tran Oil Cooler: NONE
 Inlet Conn: 1-1/4
 Outlet Conn: 1-1/4
 Eng Oil Cooler: 10(Concentric)

95- Stratus

LT0276

DPI:1703

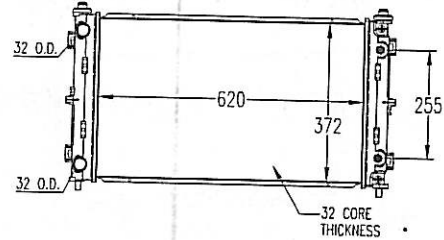

Core Size: 24-7/16x14-5/8x1-1/4

Inlet Header: 15-5/8x2-3/8
 Outlet Header: 15-5/8x2-3/8
 Tran Oil Cooler: NONE
 Inlet Conn: 1-1/4
 Outlet Conn: 1-1/4
 Eng Oil Cooler: 10(Concentric)

94-96 Dakota

LT0282

DPI:1708

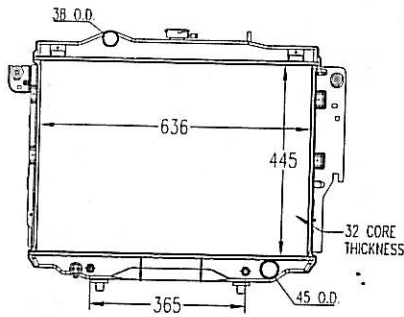

Core Size: 25x17 1/2x1 1/4

Inlet Header: 26-1/6x2-1/2
 Outlet Header: 26-1/6x2-1/2
 Tran Oil Cooler: NONE
 Inlet Conn: 1-1/2
 Outlet Conn: 1-3/4
 Eng Oil Cooler: 14-3/8(Concentric)

OEM: 52020110 / 52029031

79-03 B Series / Ram Vans

LT0084

DPI:961

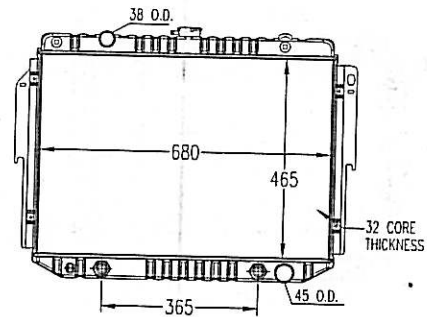

Core Size: 18-5/16x26-3/4x1-1/4

Inlet Header: 27-1/6x2
 Outlet Header: 27-1/6x2
 Tran Oil Cooler: NONE
 Inlet Conn: 1-1/2
 Outlet Conn: 1-3/4
 Eng Oil Cooler: 14-3/8(Concentric)

OEM: 4140621 / 4140623

94-01 RAM

LT0238

DPI:1552

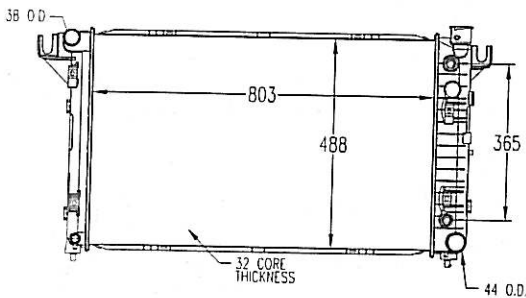

Core Size: 31-5/8x19-3/16x1-1/4

Inlet Header: 20-3/16x2-3/8
 Outlet Header: 20-3/16x2-3/8
 Tran Oil Cooler: 14-3/8(Concentric)
 Inlet Conn: 1-1/2
 Outlet Conn: 1-3/4
 Eng Oil Cooler: NONE

OEM: 52006491 / 52006491AB

MSSEAS: 608801 / 69208

LT0662

DPI:122

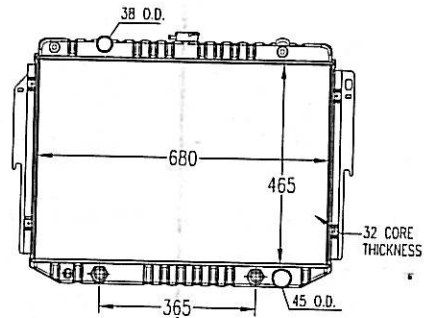

Core Size: 18-5/16x26-3/4x1-1/4

Inlet Header: 27-1/6x2
 Outlet Header: 27-1/6x2
 Tran Oil Cooler: NONE
 Inlet Conn: 1-1/2
 Outlet Conn: 1-3/4
 Eng Oil Cooler: 14-3/8(Concentric)

LT0663

DPI:1282

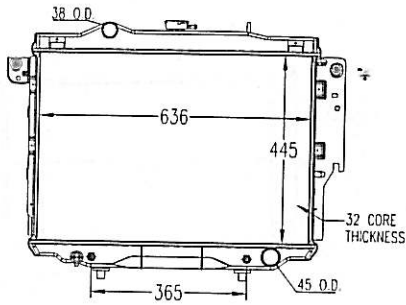

Core Size: 17-1/2×25-1/16×1-1/4
 Inlet Header: 26-1/6×2-7/16 Inlet Conn: 1-1/2
 Outlet Header: 26-1/6×2-7/16 Outlet Conn: 1-3/4
 Tran Oil Cooler: NONE Eng Oil Cooler: 14-3/8(Concentric)

OEM: 52005848 / 52005849

LT0664

DPI:1283

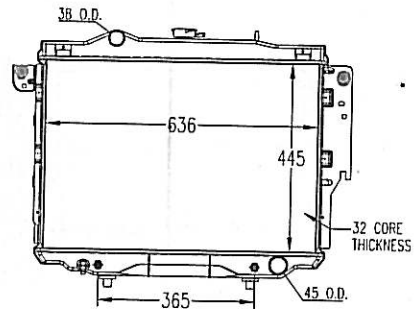

Core Size: 17-1/2×25-1/16×1-1/4
 Inlet Header: 26-1/6×2-7/16 Inlet Conn: 1-1/2
 Outlet Header: 26-1/6×2-7/16 Outlet Conn: 1-3/4
 Tran Oil Cooler: NONE Eng Oil Cooler: 14-3/8(Concentric)

OEM: 52028101 / 52028105

LT0666

DPI:1717

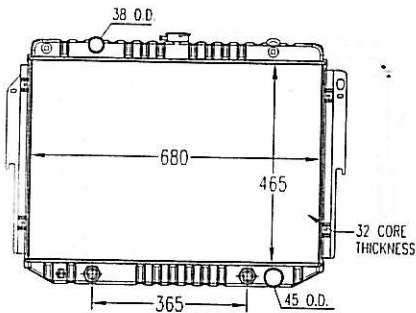

Core Size: 18-5/16×26-3/4×1-1/4
 Inlet Header: 27-1/6×2 Inlet Conn: 1-1/2
 Outlet Header: 27-1/6×2 Outlet Conn: 1-3/4
 Tran Oil Cooler: NONE Eng Oil Cooler: 14-3/8(Concentric)

OEM: 52028627 / 52029115