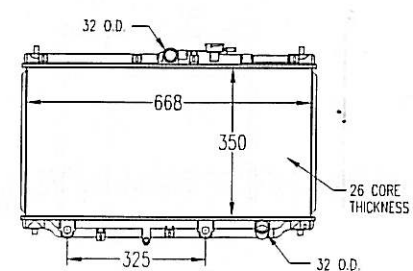
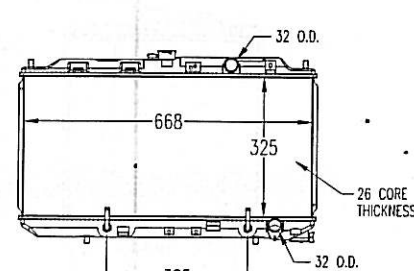
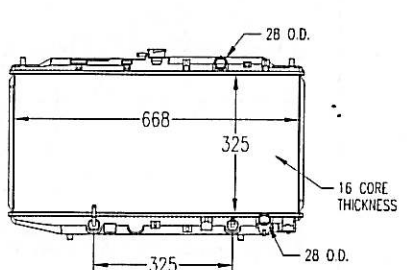
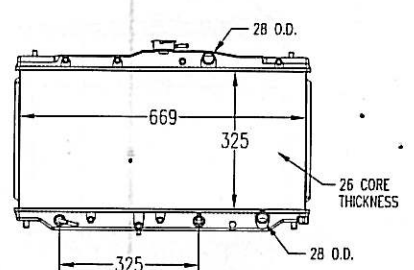
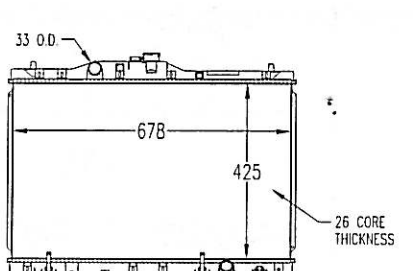
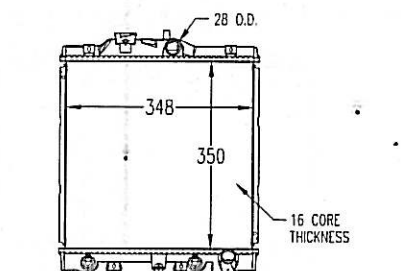
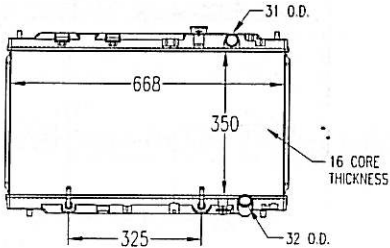
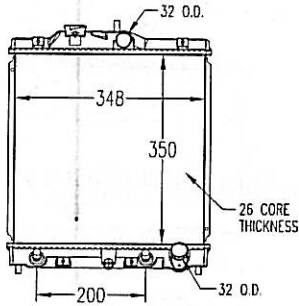
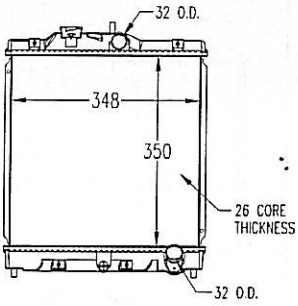
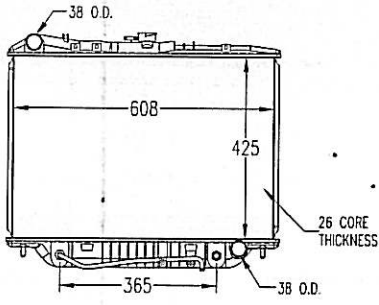
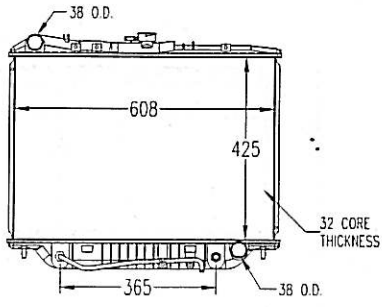
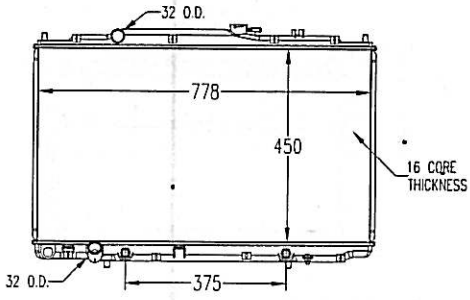
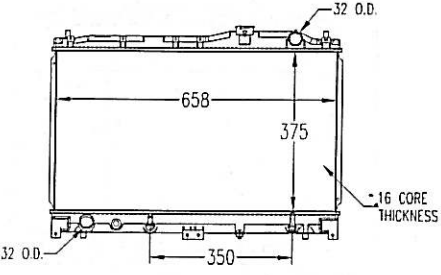
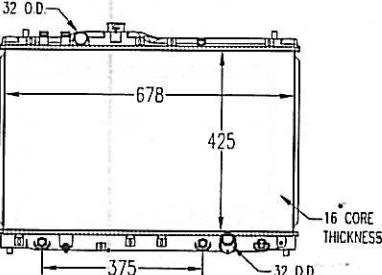
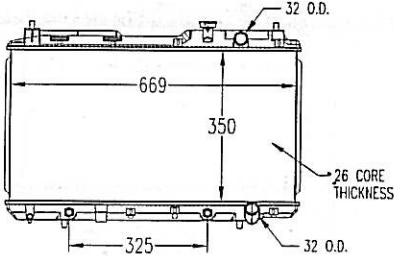
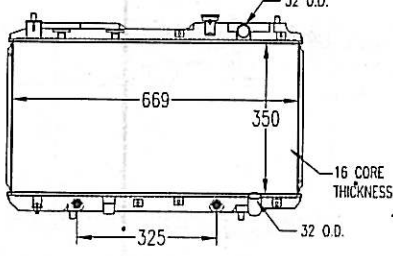
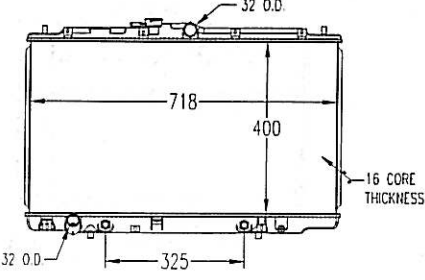
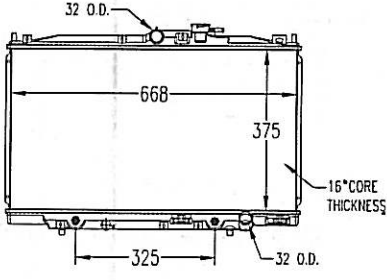
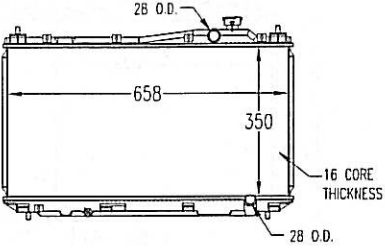
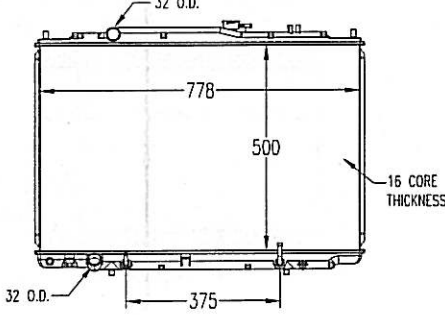
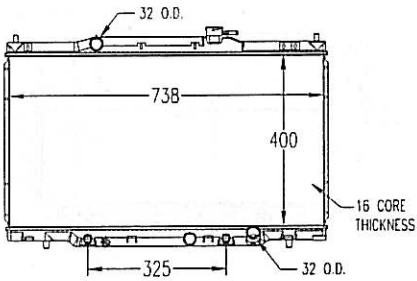
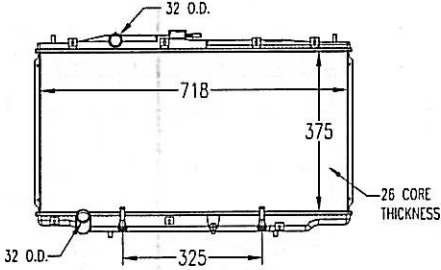
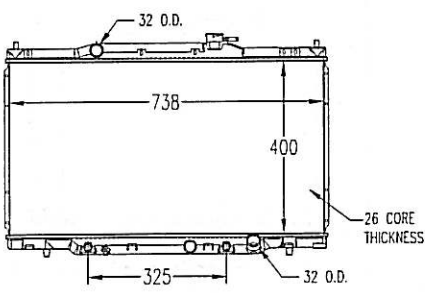
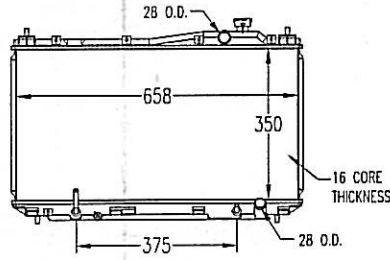

<p style="text-align: center;">90-93 Accord / Prelude</p> <p>LT0001 DPI:19</p>  <p style="text-align: center;">Core Size: 13-3/4×26-5/16×1</p> <p>Inlet Header: 27-1/16×1-15/16 Inlet Conn: 1-1/4 Outlet Header: 27-1/16×1-15/16 Outlet Conn: 1-1/4 Tran Oil Cooler: NONE Eng Oil Cooler: 12-13/16(Concentric)</p> <p>OEM: 19010-PT1-905 / 19010-PT1-908 NISSENS: 622831</p>	<p style="text-align: center;">90-93 Integra / Acura Integra</p> <p>LT0032 DPI:292</p>  <p style="text-align: center;">Core Size: 12-13/16×26-5/16×1</p> <p>Inlet Header: 27-1/16×1-15/16 Inlet Conn: 1-1/4 Outlet Header: 27-1/16×1-15/16 Outlet Conn: 1-1/4 Tran Oil Cooler: NONE Eng Oil Cooler: 12-13/16(Concentric)</p> <p>OEM: 19010-PR3-902 / 19010-PR3-903</p>
<p style="text-align: center;">88-91 Civic / CRX</p> <p>LT0062 DPI:886</p>  <p style="text-align: center;">Core Size: 12-13/16×26-5/16×5/8</p> <p>Inlet Header: 27-1/16×1-9/16 Inlet Conn: 1-1/16 Outlet Header: 27-1/16×1-15/16 Outlet Conn: 1-1/16 Tran Oil Cooler: NONE Eng Oil Cooler: 12-13/16(Concentric)</p> <p>OEM: 19010-PM3-901 / 19010-PM3-902</p>	<p style="text-align: center;">86-89 Accord</p> <p>LT0073 DPI:928</p>  <p style="text-align: center;">Core Size: 12-13/16×26-5/16×1</p> <p>Inlet Header: 27-1/16×1-15/16 Inlet Conn: 1-1/16 Outlet Header: 27-1/16×1-15/16 Outlet Conn: 1-1/16 Tran Oil Cooler: NONE Eng Oil Cooler: 12-13/16(Concentric)</p> <p>OEM: 19010-PK1-675 / 19010-PK3-A51</p>
<p style="text-align: center;">91-95 Acura Legend ,91-95 Acura Legend(16mm)</p> <p>LT0139 DPI:1278</p>  <p style="text-align: center;">Core Size: 16-3/4×26-11/16×1</p> <p>Inlet Header: 27-1/2×1-7/8 Inlet Conn: 1-5/16 Outlet Header: 27-1/2×1-7/8 Outlet Conn: 1-5/16 Tran Oil Cooler: NONE Eng Oil Cooler: 14-3/4(Concentric)</p> <p>OEM: 19010-PY3-505 / 19010-PY3-901</p>	<p style="text-align: center;">92-98 Civic / Del Sol(16mm) , 98-00 Seville , 92-98 Civic / Del Sol(26mm)</p> <p>LT0141 DPI:1290</p>  <p style="text-align: center;">Core Size: 13-3/4×13-11/16×5/8</p> <p>Inlet Header: 14-9/16×1-7/8 Inlet Conn: 1-1/16 Outlet Header: 14-9/16×1-7/8 Outlet Conn: 1-1/16 Tran Oil Cooler: NONE Eng Oil Cooler: 7-7/8(Concentric)</p> <p>OEM: 19010-P2A-901 / 19010-P03-903 NISSENS: 633081</p>

92-98 Civic / Del SOL			
LT0142	DPI:1290	LT0447	DPI:2273
Core Size: 13-3/4×13-11/16×1		Core Size: 13-3/4×13-11/16×1	
Inlet Header: 14-9/16×1-7/8	Inlet Conn: 1-1/16	Inlet Header: 14-9/16×1-7/8	Inlet Conn: 1-1/16
Outlet Header: 14-9/16×1-7/8	Outlet Conn: 1-1/16	Outlet Header: 14-9/16×1-7/8	Outlet Conn: 1-1/16
Tran Oil Cooler: NONE	Eng Oil Cooler: 7-7/8(Concentric)	Tran Oil Cooler: NONE	Eng Oil Cooler: 7-7/8(Concentric)
OEM: 19010-P28-G51 / 19010-P2J-902			
92-97 Acura SLX / Isuzu Trooper		92-96 Camry 4cyl , 92-96 Camry 4cyl(16mm)	
LT0146	DPI:1302	LT0152	DPI:1318
Core Size: 19-2/3×24×1		Core Size: 16-3/4×28-1/4×5/8	
Inlet Header: 25×2	Inlet Conn: 1-1/2	Inlet Header: 29×1-5/16	Inlet Conn: 1-1/4
Outlet Header: 25×2	Outlet Conn: 1-1/2	Outlet Header: 29×1-7/8	Outlet Conn: 1-1/4
Tran Oil Cooler: NONE	Eng Oil Cooler: 14-3/8(Concentric)	Tran Oil Cooler: NONE	Eng Oil Cooler: 14-3/4(Concentric)
OEM: 8943752755/8943752765		OEM: 16400-74880 NISSENS: 647681	
98-02 Accord 4cyl		94-97 Accord/Prelude/Acura CL 2.2 L	
LT0405	DPI:2158	LT0217	DPI:1494
Core Size: 14-3/4×26-5/16×5/8		Core Size: 13-3/4×26-11/16×5/8	
Inlet Header: 27×1-9/16	Inlet Conn: 1-1/4	Inlet Header: 27-1/2×1-5/16	Inlet Conn: 1-1/4
Outlet Header: 27×1-15/16	Outlet Conn: 1-1/4	Outlet Header: 27-1/2×1-7/8	Outlet Conn: 1-1/4
Tran Oil Cooler: NONE	Eng Oil Cooler: NONE	Tran Oil Cooler: NONE	Eng Oil Cooler: 12-13/16(Concentric)
OEM: 19010-PAA-A02		OEM: 19010-POD-J51 /-POD-J54 NISSENS: 633141	

94-01 Integra / Acura Integra		92-98 Civic / Del Sol	
LT0246 DPI:1568  <p>Core Size: 13-3/4×26-5/16×5/8</p> <p>Inlet Header: 27-1/16×1-9/16 Inlet Conn: 1-1/6 Outlet Header: 27-1/16×1-15/16 Outlet Conn: 1-1/4 Tran Oil Cooler: NONE Eng Oil Cooler: 12-13/16(Concentric)</p> <p>OEM: 19010-P72-003 / 19010-P72-9030M NISSENS: 640941</p>	LT0247 DPI:1570  <p>Core Size: 13-3/4×13-11/16×1</p> <p>Inlet Header: 14-9/16×1-7/8 Inlet Conn: 1-1/4 Outlet Header: 14-9/16×1-7/8 Outlet Conn: 1-1/4 Tran Oil Cooler: NONE Eng Oil Cooler: 7-7/8(Concentric)</p> <p>OEM: 19010-P1E-A51 / 19010-PEA-901-19010-PEA-9010M</p>		
98-02 Accord 4cyl / Avancier		94-97 Passport, Isuzu Rodeo/Vehicross 94-97 Passport, Isuzu Rodeo/Vehicross (32mm)	
LT0248 DPI:1570  <p>Core Size: 13-3/4×13-11/16×1</p> <p>Inlet Header: 14-9/16×1-7/8 Inlet Conn: 1-1/4 Outlet Header: 14-9/16×1-7/8 Outlet Conn: 1-1/4 Tran Oil Cooler: NONE Eng Oil Cooler: NONE</p> <p>OEM: 19010-P30-505 / 19010-P30-601 / 19010-P30-G20</p>	LT0249 DPI:1571  <p>Core Size: 16-3/4×24×1</p> <p>Inlet Header: 25×2 Inlet Conn: 1-1/2 Outlet Header: 25×2 Outlet Conn: 1-1/2 Tran Oil Cooler: NONE Eng Oil Cooler: 14-3/8(Concentric)</p> <p>OEM: 8524759590/8524759600</p>		
94-97 Passport, Isuzu Rodeo/Vehicross 94-97 Passport, Isuzu Rodeo/Vehicross (32mm)		99-04 Odyssey 6cyl	
LT0250 DPI:1571  <p>Core Size: 16-3/4×24×1-1/4</p> <p>Inlet Header: 25×2 Inlet Conn: 1-1/2 Outlet Header: 25×2 Outlet Conn: 1-1/2 Tran Oil Cooler: NONE Eng Oil Cooler: 14-3/8(Concentric)</p>	LT0444 DPI:2270  <p>Core Size: 17-3/4×30-5/8×5/8</p> <p>Inlet Header: 31-5/16×1-5/16 Inlet Conn: 1-1/4 Outlet Header: 31-5/16×1-7/8 Outlet Conn: 1-1/4 Tran Oil Cooler: NONE Eng Oil Cooler: 14-3/4(Concentric)</p> <p>OEM: 19010-P8F-J51</p>		

<p>95-98 Acura TL 2.5L / Inspire / Saber LT0367 DPI:2030</p>  <p>Core Size: 14-3/4×26×5/8 Inlet Header: 26-11/16×1-1/4 Outlet Header: 26-11/16×1-7/8 Tran Oil Cooler: NONE Inlet Conn: 1-1/4 Outlet Conn: 1-1/4 Eng Oil Cooler: 13-3/4(Concentric)</p> <p>OEM: 19010-P1R-901 / 19010-P1R-902</p>	<p>95-98 Acura TL 3.2L / Inspire / Saber LT0368 DPI:2031</p>  <p>Core Size: 16-3/4×26-11/16×5/8 Inlet Header: 27-1/2×1-5/16 Outlet Header: 27-1/2×1-7/8 Tran Oil Cooler: NONE Inlet Conn: 1-1/4 Outlet Conn: 1-1/4 Eng Oil Cooler: 14-3/4(Concentric)</p> <p>OEM: 19010-P5G-901</p>
<p>97-01 CRV LT0374 DPI:2051</p>  <p>Core Size: 13-3/4×26-5/16×1 Inlet Header: 27-1/16×1-15/16 Outlet Header: 27-1/16×1-15/16 Tran Oil Cooler: NONE Inlet Conn: 1-1/4 Outlet Conn: 1-1/4 Eng Oil Cooler: 12-13/16(Concentric)</p> <p>OEM: 19010-P3F-901 / 19010-P3F-902 NISSENS: 681021</p>	<p>97-01 CRV LT0375 DPI:2051</p>  <p>Core Size: 13-3/4×26-15/16×5/8 Inlet Header: 27×2 Outlet Header: 27×2 Tran Oil Cooler: NONE Inlet Conn: 1-1/4 Outlet Conn: 1-1/4 Eng Oil Cooler: 12-13/16(Concentric)</p> <p>OEM: 19010-P3F-901 / 19010-P3F-902</p>
<p>98-02 Accord / Acura TL 3.2L / Inspire / Saber LT0398 DPI:2147</p>  <p>Core Size: 15-3/4×28-1/4×5/8 Inlet Header: 29×1-5/16 Outlet Header: 29×1-7/8 Tran Oil Cooler: NONE Inlet Conn: 1-1/4 Outlet Conn: 1-1/4 Eng Oil Cooler: 12-13/16(Concentric)</p> <p>OEM: 19010-P8B-J51 / 19010-P8C-A51</p>	<p>98-02 Accord 4cyl / Avancier 98-02 Accord 4cyl LT0399 DPI:2148</p>  <p>Core Size: 14-3/4×26-5/16×5/8 Inlet Header: 27×1-9/16 Outlet Header: 27×1-9/16 Tran Oil Cooler: NONE Inlet Conn: 1-1/4 Outlet Conn: 1-1/4 Eng Oil Cooler: 12-4/5(Concentric)</p> <p>OEM: 19010-PAA-A51 / 19010-PAA-A53 NISSENS: 63345</p>

<p>01-05 Civic LT0507 DPI:2355</p>  <p>Core Size: 13-3/4×26×5/8</p> <p>Inlet Header: 26-11/16×1-5/16 Inlet Conn: 1-1/8 Outlet Header: 26-11/16×1-5/16 Outlet Conn: 1-1/8 Tran Oil Cooler: NONE Eng Oil Cooler: NONE</p> <p>OEM: 19010-PMM-A01 / 19010-PMM-A02</p>	<p>01-02 Acura MDX / 03-04 Pilot LT0544 DPI:2417</p>  <p>Core Size: 19-2/3×30-5/8×5/8</p> <p>Inlet Header: 31-3/10×1-5/16 Inlet Conn: 1-1/4 Outlet Header: 31-3/10×1-7/8 Outlet Conn: 1-1/4 Tran Oil Cooler: NONE Eng Oil Cooler: 14-3/4(Concentric)</p> <p>OEM: 19010-PGK-A51</p>
<p>02-06 CRV / 03-06 Element(16mm) 02-06 CRV / 03-06 Element (26mm) LT0556 DPI:2443</p>  <p>Core Size: 15-3/4×29×5/8</p> <p>Inlet Header: 29-3/4×1-7/8 Inlet Conn: 1-1/4 Outlet Header: 29-3/4×1-7/8 Outlet Conn: 1-1/4 Tran Oil Cooler: NONE Eng Oil Cooler: 12-13/16(Concentric)</p> <p>OEM: 19010-PPA-A51 / 19010-P2D-A51</p>	<p>03-07 Accord 6cyl / Inspire LT0597 DPI:2571</p>  <p>Core Size: 14-3/4×28-1/4×1</p> <p>Inlet Header: 29×1-7/8 Inlet Conn: 1-1/4 Outlet Header: 29×1-7/8 Outlet Conn: 1-1/4 Tran Oil Cooler: NONE Eng Oil Cooler: 12-13/16(Concentric)</p> <p>OEM: 19010-RDV-J510 / 19010-RCA-A51</p>
<p>02-06 CRV / 03-06 Element LT0557 DPI:2443</p>  <p>Core Size: 15-3/4×29×1</p> <p>Inlet Header: 29-3/4×1-7/8 Inlet Conn: 1-1/4 Outlet Header: 29-3/4×1-7/8 Outlet Conn: 1-1/4 Tran Oil Cooler: NONE Eng Oil Cooler: 12-13/16(Concentric)</p> <p>OEM: 19010-PPA-A51 / 19010-P2D-A51</p>	<p>01-05 Civic LT0506 DPI:2354</p>  <p>Core Size: 13-3/4×26×5/8</p> <p>Inlet Header: 26-11/16×1-5/16 Inlet Conn: 1-1/8 Outlet Header: 26-11/16×1-5/16 Outlet Conn: 1-1/8 Tran Oil Cooler: NONE Eng Oil Cooler: 14-3/4(Concentric)</p> <p>OEM: 19010-PLC901 / 19010-PLC-J51</p>

HONDA

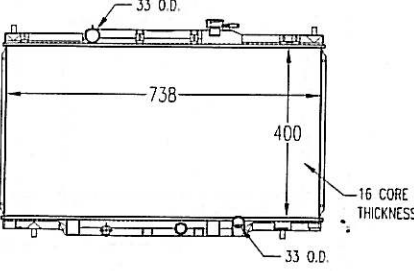
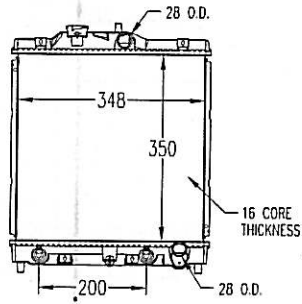
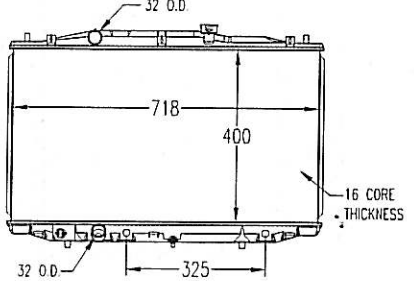
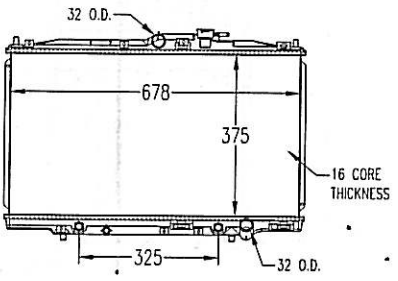
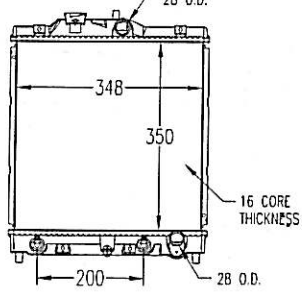
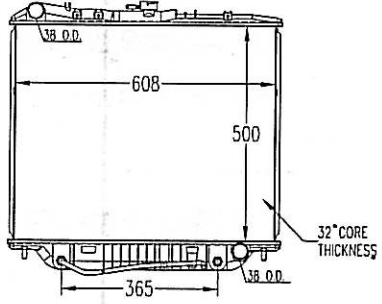
<p>02-06 CRV / 03-06 Element</p> <p>LT0558 DPI:2444</p>  <p>Core Size: 15-3/4×29×5/8</p> <p>Inlet Header: 29-3/4×1-7/8 Inlet Conn: 1-5/16 Outlet Header: 29-3/4×1-7/8 Outlet Conn: 1-5/16 Tran Oil Cooler: NONE Eng Oil Cooler: NONE</p> <p>OEM: 19010-PPA-A01 / 19010-PNB-003</p>	<p>92-98 Civic / Del Sol(16mm) , 98-00 Seville , 92-98 Civic / Del Sol(26mm)</p> <p>LT0157 DPI:1328</p>  <p>Core Size: 13-3/4×13-11/16×5/8</p> <p>Inlet Header: 14-9/16×1-7/8 Inlet Conn: 1-1/16 Outlet Header: 14-9/16×1-7/8 Outlet Conn: 1-1/16 Tran Oil Cooler: NONE Eng Oil Cooler: 7-7/8(Concentric)</p> <p>OEM: 19010-P2A-901 / 19010-P03-903 NISSENS: 633081</p>
<p>03-04 Accord 4cyl</p> <p>LT0595 DPI:2569</p>  <p>Core Size: 15-3/4×28-1/4×5/8</p> <p>Inlet Header: 29×1-5/16 Inlet Conn: 1-1/4 Outlet Header: 29×1-7/8 Outlet Conn: 1-1/4 Tran Oil Cooler: NONE Eng Oil Cooler: 12-13/16(Concentric)</p> <p>OEM: 19010-RAA-A51 / 19010-RAA-A01</p>	<p>98-02 Accord 4cyl</p> <p>LT0417 DPI:2203</p>  <p>Core Size: 14-3/4×26-11/16×5/8</p> <p>Inlet Header: 27-1/2×1-5/16 Inlet Conn: 1-1/4 Outlet Header: 27-1/2×1-7/8 Outlet Conn: 1-1/4 Tran Oil Cooler: NONE Eng Oil Cooler: 12-13/16(Concentric)</p> <p>OEM: 19010-PAA-A02</p>
<p>92-98 Civic / Del Sol(16mm) , 98-00 Seville , 92-98 Civic / Del Sol(26mm)</p> <p>LT0448 DPI:2274</p>  <p>Core Size: 13-3/4×13-11/16×5/8</p> <p>Inlet Header: 14-9/16×1-7/8 Inlet Conn: 1-1/16 Outlet Header: 14-9/16×1-7/8 Outlet Conn: 1-1/16 Tran Oil Cooler: NONE Eng Oil Cooler: 7-7/8(Concentric)</p> <p>OEM: 19010-P2A-901 / 19010-P03-903 NISSENS: 633081</p>	<p>92-97 Acura SLX/Isuzu Trooper</p> <p>LT0640 DPI:1302</p>  <p>Core Size: 19-2/3×24×1-1/4</p> <p>Inlet Header: 25×2 Inlet Conn: 1-1/2 Outlet Header: 25×2 Outlet Conn: 1-1/2 Tran Oil Cooler: NONE Eng Oil Cooler: 14-3/8(Concentric)</p> <p>OEM: 8943752755/8943752765</p>

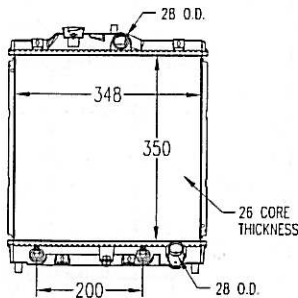
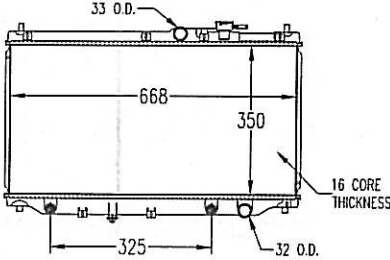
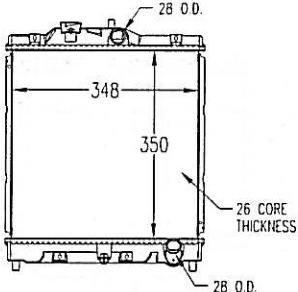
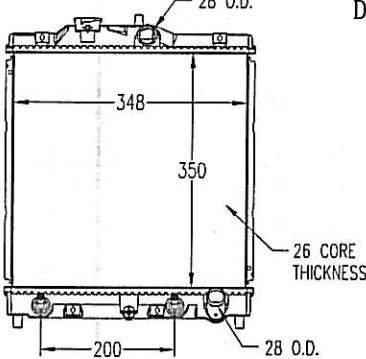
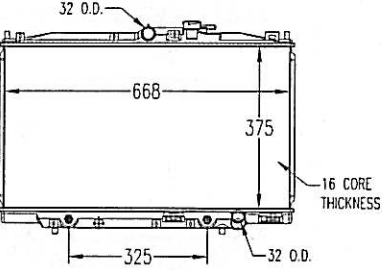
		90-93 Accord / Prelude	
LT0641  Core Size: 13-3/4×13-11/16×1 Inlet Header: 14-9/16×1-7/8 Outlet Header: 14-9/16×1-7/8 Tran Oil Cooler: NONE Inlet Conn: 1-1/16 Outlet Conn: 1-1/16 Eng Oil Cooler: 7-7/8(Concentric)	DPI:2274	LT0642  Core Size: 13-3/4×26-5/16×5/8 Inlet Header: 27×2 Outlet Header: 27×2 Tran Oil Cooler: NONE Inlet Conn: 1-5/16 Outlet Conn: 1-1/4 Eng Oil Cooler: 12-13/16(Concentric)	DPI:19
OEM: 19010-P28-G51 / 19010-P2J-902		OEM: 19010-PT1-905 / 19010-PT1-908	
HONDA CIVIC 92-98			
LT0643  Core Size: 13-3/4×13-11/16×1 Inlet Header: 14-9/16×1-7/8 Outlet Header: 14-9/16×1-7/8 Tran Oil Cooler: NONE Inlet Conn: 1-1/16 Outlet Conn: 1-1/16 Eng Oil Cooler: NONE	DPI:1290	LT0644  Core Size: 13-3/4×13-11/16×1 Inlet Header: 14-9/16×1-7/8 Outlet Header: 14-9/16×1-7/8 Tran Oil Cooler: NONE Inlet Conn: 1-1/16 Outlet Conn: 1-1/16 Eng Oil Cooler: 7-7/8(Concentric)	DPI:1328
		OEM: 19010-P28-G51 / 19010-P2J-902	
98-02 Accord 4cyl			
LT0683  Core Size: 14-3/4×26-5/16×5/8 Inlet Header: 27×1-9/16 Outlet Header: 27×1-15/16 Tran Oil Cooler: NONE Inlet Conn: 1-1/4 Outlet Conn: 1-1/4 Eng Oil Cooler: 12-13/16(Concentric)	DPI:2203		
OEM: 19010-PAA-A51 / 19010-PAA-A53			