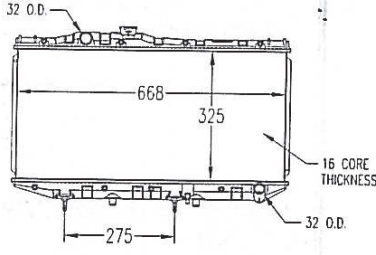
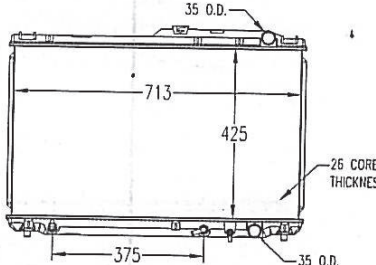
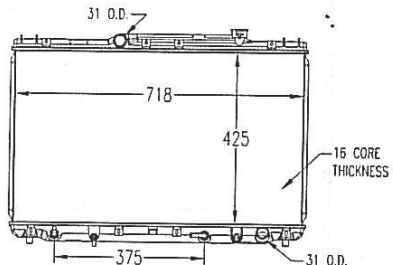
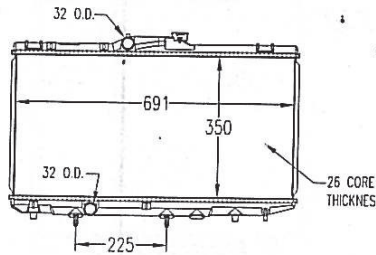
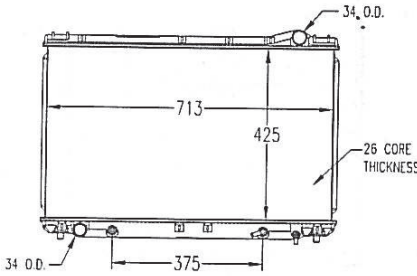
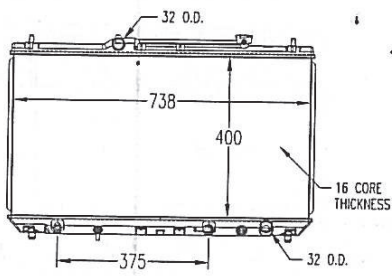
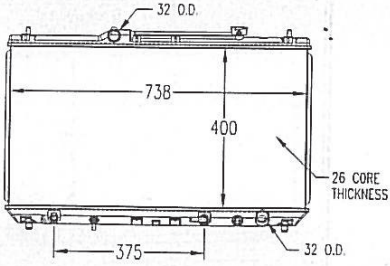
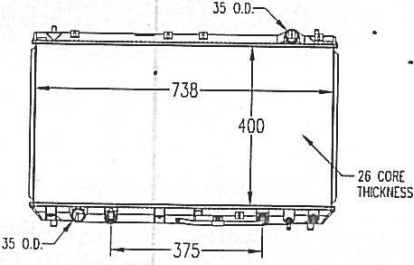
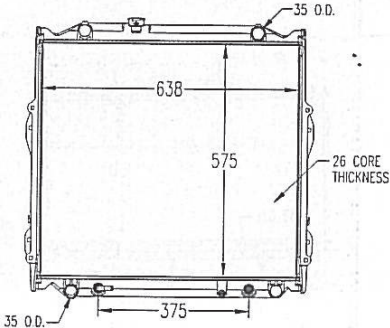
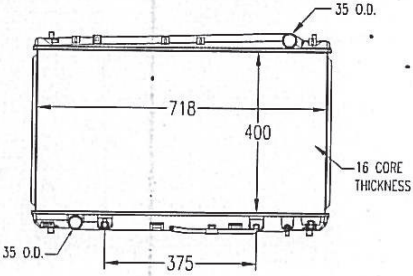
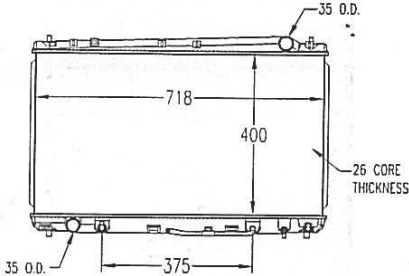
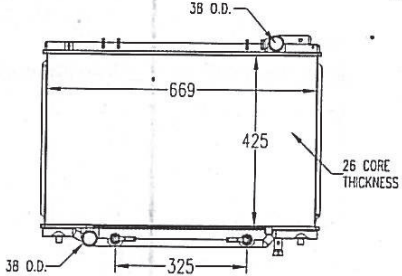

TOYOTA

<p>87-91 Camry</p> <p>LT0061</p> <p>DPI:870</p>  <p>Core Size: 12-13/16×26-5/16×5/8</p> <p>Inlet Header: 27-1/16×1-9/16 Inlet Conn: 1-1/4 Outlet Header: 27-1/16×1-15/16 Outlet Conn: 1-1/4 Tran Oil Cooler: NONE Eng Oil Cooler: 10-13/16(Concentric)</p> <p>OEM: 16400-74130 / 16400-74450</p>	<p>92-93 Camry, Lexus ES 300 92-93 Camry, Lexus ES 300(26mm)</p> <p>LT0147</p> <p>DPI:1303</p>  <p>Core Size: 16-3/4×28-1/16×1</p> <p>Inlet Header: 29×1-7/8 Inlet Conn: 1-3/8 Outlet Header: 29×1-7/8 Outlet Conn: 1-3/8 Tran Oil Cooler: NONE Eng Oil Cooler: 14-3/4(Concentric)</p> <p>OEM: 16400-62100 NISSENS: 647721</p>
<p>92-96 Camry 4cyl 92-96 Camry 4cyl(16mm)</p> <p>LT0152</p> <p>DPI:1318</p>  <p>Core Size: 16-3/4×28-1/4×5/8</p> <p>Inlet Header: 29×1-5/16 Inlet Conn: 1-1/4 Outlet Header: 29×1-7/8 Outlet Conn: 1-1/4 Tran Oil Cooler: NONE Eng Oil Cooler: 14-3/4(Concentric)</p> <p>OEM: 16400-74880 NISSENS: 647681</p>	<p>93-97 Corolla DX , CEO Prizm</p> <p>LT0183</p> <p>DPI:1409</p>  <p>Core Size: 13-3/4×27-3/16×1</p> <p>Inlet Header: 28-1/16×1-7/8 Inlet Conn: 1-1/4 Outlet Header: 28-1/16×1-7/8 Outlet Conn: 1-1/4 Tran Oil Cooler: NONE Eng Oil Cooler: 8-7/8(Concentric)</p> <p>OEM: 16400-11550 / 16400-16700</p>
<p>94-96 Camry, Lexus ES 300(26mm) 94-96 Camry, Lexus ES 300(16mm)</p> <p>LT0292</p> <p>DPI:1746</p>  <p>Core Size: 16-3/4×28-1/16×1</p> <p>Inlet Header: 29×1-7/8 Inlet Conn: 1-5/16 Outlet Header: 29×1-7/8 Outlet Conn: 1-5/16 Tran Oil Cooler: NONE Eng Oil Cooler: 14-3/4(Concentric)</p> <p>OEM: 16400-0A030/ 16400-0A020 NISSENS: 647531</p>	<p>97-01 Camry / Solara(16mm) 97-01 Camry / Solara(26mm)</p> <p>LT0345</p> <p>DPI:1909(16)</p>  <p>Core Size: 15-3/4×29-1/16×5/8</p> <p>Inlet Header: 29-3/4×1-5/16 Inlet Conn: 1-1/4 Outlet Header: 29-3/4×1-7/8 Outlet Conn: 1-1/4 Tran Oil Cooler: NONE Eng Oil Cooler: 14-3/4(Concentric)</p> <p>OEM: 16400-7A310 / 16400-7A311</p>

TOYOTA

<p>97-01 Camry / Solara LT0346 DPI:1909(26)</p>  <p>Core Size: 15-3/4×29-1/16×1 Inlet Header: 29-3/4×1-5/16 Inlet Conn: 1-1/4 Outlet Header: 29-3/4×1-7/8 Outlet Conn: 1-1/4 Tran Oil Cooler: NONE Eng Oil Cooler: 14-3/4(Concentric)</p> <p>OEM: 16400-7A310 / 16400-7A311 NISSENS: 646991</p>	<p>97-01 Camry/Solara , Lexus ES 300 LT0347 DPI:1910</p>  <p>Core Size: 15-3/4×29-1/16×1 Inlet Header: 29-3/4×1-7/8 Inlet Conn: 1-3/8 Outlet Header: 29-3/4×1-7/8 Outlet Conn: 1-3/8 Tran Oil Cooler: NONE Eng Oil Cooler: 14-3/4(Concentric)</p> <p>OEM: 16400-20090 / 16400-20091 NISSENS: 647541</p>
<p>96-02 4 Runner LT0358 DPI:1998</p>  <p>Core Size: 22-5/8×25-1/8×1 Inlet Header: 25-15/16×1-7/8 Inlet Conn: 1-3/8 Outlet Header: 25-15/16×1-7/8 Outlet Conn: 1-3/8 Tran Oil Cooler: NONE Eng Oil Cooler: 14-3/4(Concentric)</p> <p>OEM: 16400-75190 / 16400-75191 NISSENS: 647551</p>	<p>00-04 Avalon / Standard Duty LT0479 DPI:2324</p>  <p>Core Size: 15-3/4×28-1/4×5/8 Inlet Header: 29×1-7/8 Inlet Conn: 1-3/8 Outlet Header: 29×1-7/8 Outlet Conn: 1-3/8 Tran Oil Cooler: NONE Eng Oil Cooler: 14-3/4(Concentric)</p> <p>OEM: 16400-0A170</p>
<p>00-04 Avalon / Standard Duty LT0480 DPI:2325</p>  <p>Core Size: 15-3/4×28-1/4×1 Inlet Header: 29×1-7/8 Inlet Conn: 1-3/8 Outlet Header: 29×1-7/8 Outlet Conn: 1-3/8 Tran Oil Cooler: NONE Eng Oil Cooler: 14-3/4(Concentric)</p> <p>OEM: 16400-0A180</p>	<p>91-97 Previa Van LT0116 DPI:1155</p>  <p>Core Size: 16-3/4×26-5/16×1 Inlet Header: 27-1/16×1-15/16 Inlet Conn: 1-1/2 Outlet Header: 27-1/16×1-15/16 Outlet Conn: 1-1/2 Tran Oil Cooler: NONE Eng Oil Cooler: 12-13/16(Concentric)</p> <p>OEM: 16400-76081</p>

TOYOTA

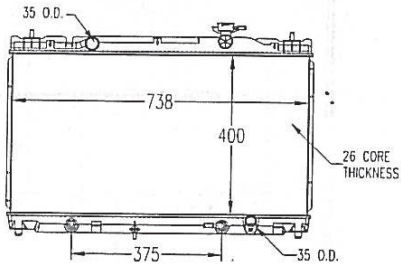
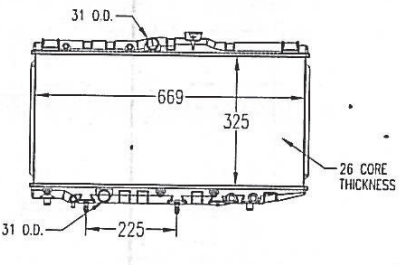
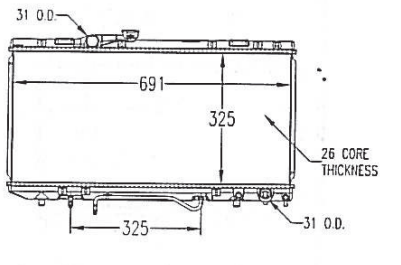
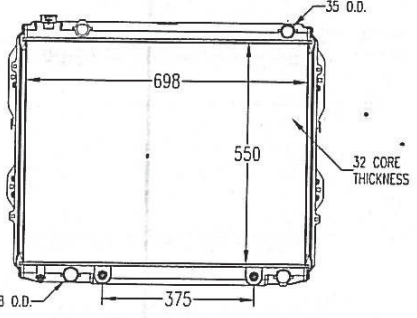
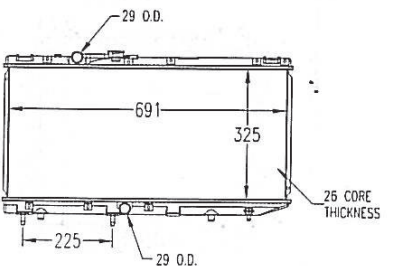
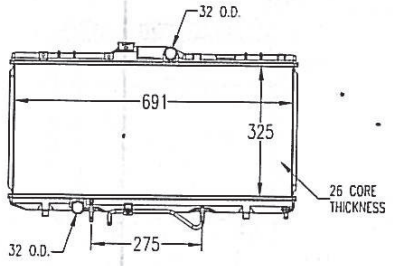
<p>02- Camry 4cyl LT0553 DPI:2436/2437</p>  <p>Core Size: 15-3/4×29-1/16×1</p> <p>Inlet Header: 29-3/4×1-7/8 Outlet Header: 29-3/4×1-7/8 Tran Oil Cooler: NONE</p> <p>Inlet Conn: 1-3/8 Outlet Conn: 1-3/8 Eng Oil Cooler: 14-3/4(Concentric)</p> <p>OEM: 16400-0H130 NISSENS: 6463351</p>	<p>88-92 Corolla LT0043 DPI:539</p>  <p>Core Size: 12-13/16×26-5/16×1</p> <p>Inlet Header: 27-1/16×1-15/16 Outlet Header: 27-1/16×1-15/16 Tran Oil Cooler: NONE</p> <p>Inlet Conn: 1-1/4 Outlet Conn: 1-1/4 Eng Oil Cooler: 8-7/8(Concentric)</p> <p>OEM: 16400-11210</p>
<p>90-93 Celica LT0120 DPI:1174</p>  <p>Core Size: 12-13/16×27-1/4×1</p> <p>Inlet Header: 1-13/16×28-1/16 Outlet Header: 1-13/16×28-1/16 Tran Oil Cooler: NONE</p> <p>Inlet Conn: 1-1/4 Outlet Conn: 1-1/4 Eng Oil Cooler: 12-13/16(Concentric)</p> <p>OEM: 16400-74500</p>	<p>00-04 Thundra LT0476 DPI:2320</p>  <p>Core Size: 21-5/8×27-1/2×1-1/4</p> <p>Inlet Header: 2-3/16×28-3/16 Outlet Header: 2-3/16×28-3/16 Tran Oil Cooler: NONE</p> <p>Inlet Conn: 1-3/8 Outlet Conn: 1-1/2 Eng Oil Cooler: 14-3/4(Concentric)</p> <p>OEM: 16400-07090</p>
<p>91-94 Tercel / Paseo LT0153 DPI:1319</p>  <p>Core Size: 12-13/16×27-1/4×1</p> <p>Inlet Header: 28-1/4×1-7/8 Outlet Header: 28-1/4×1-7/8 Tran Oil Cooler: NONE</p> <p>Inlet Conn: 1-1/6 Outlet Conn: 1-1/6 Eng Oil Cooler: 8-7/8(Concentric)</p> <p>OEM: 16400-11460 / 16400-11530</p>	<p>90-93 Celica LT0179 DPI:1407</p>  <p>Core Size: 12-13/16×27-1/4×1</p> <p>Inlet Header: 28×1-7/8 Outlet Header: 28×1-7/8 Tran Oil Cooler: NONE</p> <p>Inlet Conn: 1-1/4 Outlet Conn: 1-1/4 Eng Oil Cooler: 10-5/8(Concentric)</p> <p>OEM: 16400-16390</p>

TOYOTA

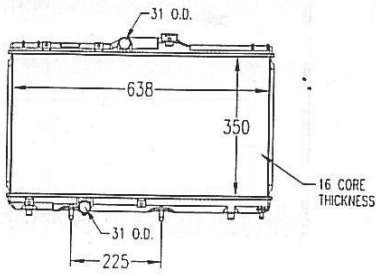
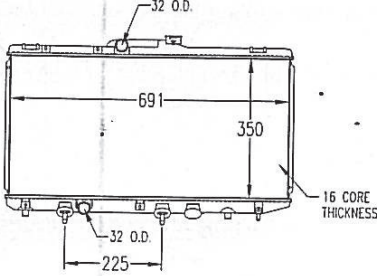
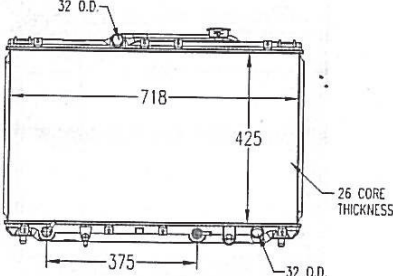
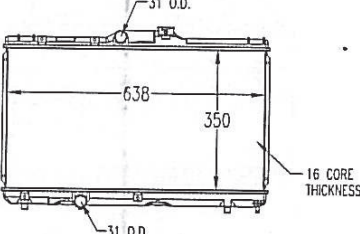
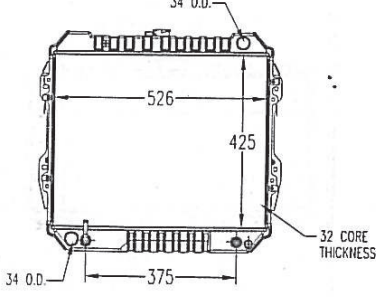
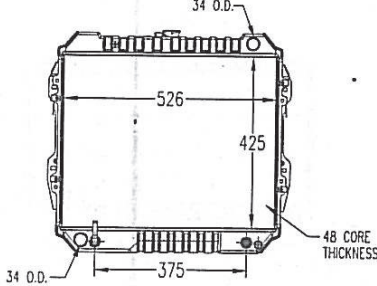
<p style="text-align: center;">93-97 Corolla</p> <p>LT0180 DPI:1408</p>  <p style="text-align: center;">Core Size: 13-3/4×25-1/8×5/8</p> <p>Inlet Header: 26×1-2/7 Outlet Header: 26×1-2/7 Tran Oil Cooler: NONE</p> <p style="text-align: right;">Inlet Conn: 1-1/4 Outlet Conn: 1-1/4 Eng Oil Cooler: 8-7/8(Concentric)</p> <p style="text-align: center;">OEM: 16400-15500 / 16400-15501</p>	<p style="text-align: center;">93-97 Corolla DX ,CEO Prizm(16mm)</p> <p>LT0182 DPI:1409</p>  <p style="text-align: center;">Core Size: 13-3/4×27-13/16×5/8</p> <p>Inlet Header: 28-1/16×1-7/8 Outlet Header: 28-1/16×1-7/8 Tran Oil Cooler: NONE</p> <p style="text-align: right;">Inlet Conn: 1-1/4 Outlet Conn: 1-1/4 Eng Oil Cooler: 8-7/8(Concentric)</p> <p style="text-align: center;">OEM: 16400-11550 / 16400-15510</p>
<p style="text-align: center;">92-96 Camry 4cyl</p> <p>LT0187 DPI:1428</p>  <p style="text-align: center;">Core Size: 16-3/4×28-1/4×1</p> <p>Inlet Header: 29×1-7/8 Outlet Header: 29×1-7/8 Tran Oil Cooler: NONE</p> <p style="text-align: right;">Inlet Conn: 1-1/4 Outlet Conn: 1-1/4 Eng Oil Cooler: 14-3/4(Concentric)</p> <p style="text-align: center;">OEM: 16400-74880</p>	<p style="text-align: center;">93-97 Corolla , GEO Prizm</p> <p>LT0205 DPI:1462</p>  <p style="text-align: center;">Core Size: 13-3/4×25-1/8×5/8</p> <p>Inlet Header: 26×1-5/16 Outlet Header: 26×1-9/16 Tran Oil Cooler: NONE</p> <p style="text-align: right;">Inlet Conn: 1-1/4 Outlet Conn: 1-1/4 Eng Oil Cooler: NONE</p> <p style="text-align: center;">OEM: 16400-15450 /-15451</p>
<p style="text-align: center;">84- Hilux / 4 Runner / Pickup</p> <p>LT0013 DPI:147(32)</p>  <p style="text-align: center;">Core Size: 16-3/4×20-3/4×1-1/4</p> <p>Inlet Header: 20-5/6×2-9/16 Outlet Header: 20-5/6×2-9/16 Tran Oil Cooler: NONE</p> <p style="text-align: right;">Inlet Conn: 1-9/16 Outlet Conn: 1-9/16 Eng Oil Cooler: 14-3/4(Concentric)</p> <p style="text-align: center;">OEM: 16400-35380 / 16400-35290</p>	<p style="text-align: center;">84- Hilux / 4 Runner / Pickup</p> <p>LT0014 DPI:147(48)</p>  <p style="text-align: center;">Core Size: 16-3/4×20-3/4×1-7/8</p> <p>Inlet Header: 20-5/6×2-9/16 Outlet Header: 20-5/6×2-9/16 Tran Oil Cooler: NONE</p> <p style="text-align: right;">Inlet Conn: 1-9/16 Outlet Conn: 1-9/16 Eng Oil Cooler: 14-3/4(Concentric)</p> <p style="text-align: center;">OEM: 16400-35380 / 16400-35290</p>

TOYOTA

94-99 Celica GA			
<p>LT0255</p> <p>Core Size: 13-3/4×25-1/2×1</p> <p>Inlet Header: 26-1/4×2 Outlet Header: 26-1/4×2 Tran Oil Cooler: NONE</p> <p>Inlet Conn: 1-1/4 Outlet Conn: 1-1/4 Eng Oil Cooler: 8-7/8(Concentric)</p> <p>OEM: 16400-7A090</p>	<p>DPI:1575</p>	<p>LT2016</p> <p>Core Size: 17-3/4×20-11/16×1-1/4</p> <p>Inlet Header: 20-5/8×2-9/16 Outlet Header: 20-5/8×2-9/16 Tran Oil Cooler: NONE</p> <p>Inlet Conn: 1-3/8 Outlet Conn: 1-3/8 Eng Oil Cooler: NONE</p>	<p>DPI:</p>
94-99 Celica			
<p>LT2046</p> <p>Core Size: 21-5/8×20-3/8×1</p> <p>Inlet Header: 21-7/16×2-1/6 Outlet Header: 21-7/16×2-1/6 Tran Oil Cooler: NONE</p> <p>Inlet Conn: 1-9/16 Outlet Conn: 1-9/16 Eng Oil Cooler: 14-3/4(Concentric)</p>	<p>DPI:</p>	<p>LT0294</p> <p>Core Size: 13-3/4×25-1/2×1</p> <p>Inlet Header: 26-1/4×2 Outlet Header: 26-1/4×2 Tran Oil Cooler: NONE</p> <p>Inlet Conn: 1-1/4 Outlet Conn: 1-1/4 Eng Oil Cooler: 12-13/16(Concentric)</p> <p>OEM: 16400-16540</p>	<p>DPI:1748</p>
95-04 Tacoma 4WD 2.7L		95-04 Tacoma 4WD 2.4L	
<p>LT0300</p> <p>Core Size: 22-5/8×24-3/4×7/8</p> <p>Inlet Header: 25-3/4×2 Outlet Header: 25-3/4×2 Tran Oil Cooler: NONE</p> <p>Inlet Conn: 1-9/16 Outlet Conn: 1-9/16 Eng Oil Cooler: 16-3/4(Concentric)</p> <p>OEM: 16400-0C040</p>	<p>DPI:1755</p>	<p>LT0302</p> <p>Core Size: 20-5/8×24-3/4×7/8</p> <p>Inlet Header: 25-3/4×2 Outlet Header: 25-3/4×2 Tran Oil Cooler: NONE</p> <p>Inlet Conn: 1-9/16 Outlet Conn: 1-9/16 Eng Oil Cooler: 16-3/4(Concentric)</p> <p>OEM: 16400-07060</p>	<p>DPI:1774</p>

TOYOTA

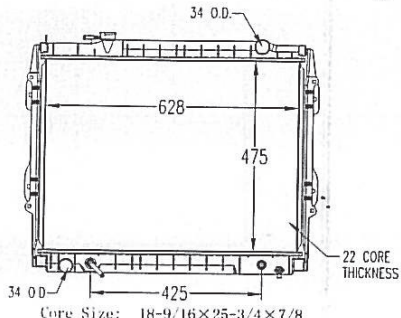
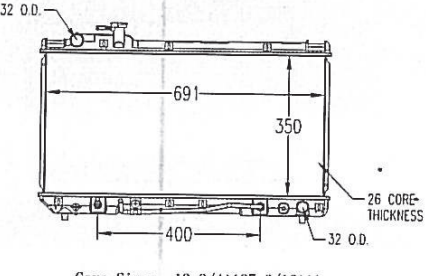
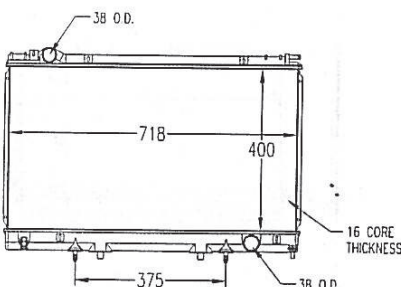
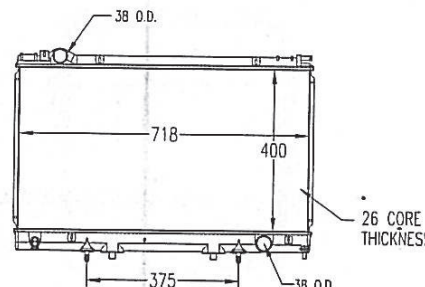
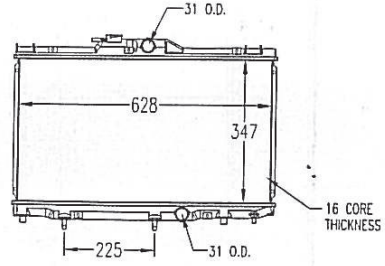
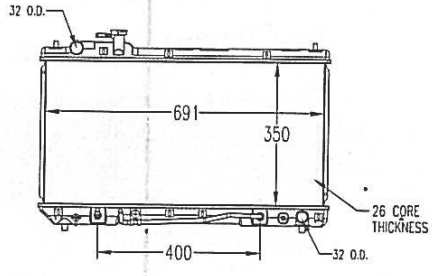
<p>95-04 Tacoma 2WD (26mm) 95-04 Tacoma 2WD (16mm)</p> <p>LT0305 DPI:1778</p>  <p>Core Size: 18-9/16×25-3/4×7/8</p> <p>Inlet Header: 25-3/4×2 Inlet Conn: 1-9/16 Outlet Header: 25-3/4×2 Outlet Conn: 1-9/16 Tran Oil Cooler: NONE Eng Oil Cooler: 14-3/4 (Concentric)</p> <p>OEM: 16400-0C022</p>	<p>96-98 RAV4 (26mm) 96-98 RAV4 (16mm)</p> <p>LT0328 DPI:1859</p>  <p>Core Size: 13-3/4×27-3/16×1</p> <p>Inlet Header: 28-5/16×1-7/8 Inlet Conn: 1-1/4 Outlet Header: 28-5/16×1-7/8 Outlet Conn: 1-1/4 Tran Oil Cooler: NONE Eng Oil Cooler: 15-3/4 (Concentric)</p> <p>OEM: 16400-7A120 / 16400-7A121</p>
<p>95-00 Lexus LS 400 (26mm) 95-00 Lexus LS 400 (16mm)</p> <p>LT0379 DPI:2058 (16)</p>  <p>Core Size: 15-3/4×28-1/4×5/8</p> <p>Inlet Header: 29×1-7/8 Inlet Conn: 1-1/2 Outlet Header: 29×1-7/8 Outlet Conn: 1-1/2 Tran Oil Cooler: NONE Eng Oil Cooler: 14-3/4 (Concentric)</p> <p>OEM: 16400-50130 (26mm) / 16400-50130 (16mm)</p>	<p>95-00 Lexus LS 400</p> <p>LT0380 DPI:2058 (26)</p>  <p>Core Size: 15-3/4×28-1/4×1</p> <p>Inlet Header: 29×1-7/8 Inlet Conn: 1-1/2 Outlet Header: 29×1-7/8 Outlet Conn: 1-1/2 Tran Oil Cooler: NONE Eng Oil Cooler: 14-3/4 (Concentric)</p> <p>OEM: 16400-50130</p>
<p>98-02 Corolla, GEO Prizm</p> <p>LT0416 DPI:2198</p>  <p>Core Size: 13-11/16×24-3/4×5/8</p> <p>Inlet Header: 25-3/4×1-13/16 Inlet Conn: 1-1/4 Outlet Header: 25-3/4×1-13/16 Outlet Conn: 1-1/4 Tran Oil Cooler: NONE Eng Oil Cooler: 8-7/8 (Concentric)</p> <p>OEM: 16400-0D040</p>	<p>98-00 RAV 4</p> <p>LT0455 DPI:2292</p>  <p>Core Size: 13-3/4×27-3/16×1</p> <p>Inlet Header: 28-5/16×1-7/8 Inlet Conn: 1-1/4 Outlet Header: 28-5/16×1-7/8 Outlet Conn: 1-1/4 Tran Oil Cooler: NONE Eng Oil Cooler: 15-3/4 (Concentric)</p> <p>OEM: 16400-7A500</p>

TOYOTA

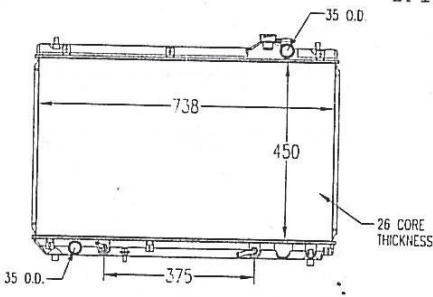
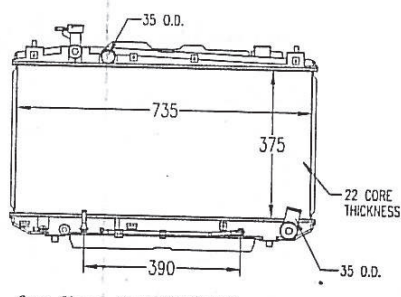
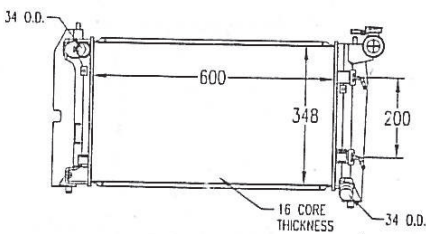
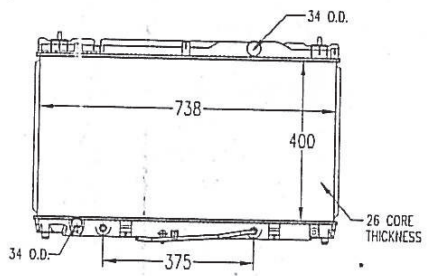
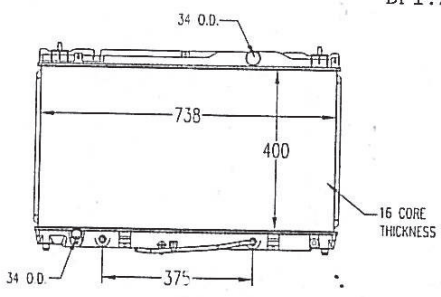
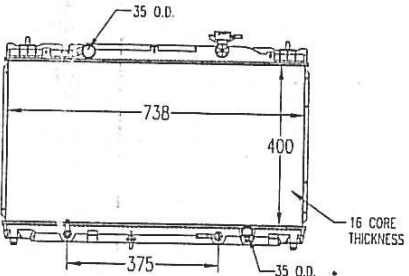
<p>01-03 Highlander 6cyl LT0518 DPI:2377</p>  <p>Core Size: 17-11/16×29×1</p> <p>Inlet Header: 29-3/4×1-7/8 Outlet Header: 29-3/4×1-7/8 Tran Oil Cooler: NONE</p> <p>Inlet Conn: 1-3/8 Outlet Conn: 1-3/8 Eng Oil Cooler: 14-3/4(Concentric)</p> <p>OEM: 16400-20140</p>	<p>01-03 RAV 4 LT0533 DPI:2403</p>  <p>Core Size: 14-3/4×29×7/8</p> <p>Inlet Header: 30×1-9/16 Outlet Header: 30×1-9/16 Tran Oil Cooler: NONE</p> <p>Inlet Conn: 1-3/8 Outlet Conn: 1-3/8 Eng Oil Cooler: 15-3/8(Concentric)</p> <p>OEM: 16400-22130 / 16400-28140</p>
<p>03-06 Corolla LT0548 DPI:2428</p>  <p>Core Size: 23-5/8×13-11/16×5/8</p> <p>Inlet Header: 14-5/8×1-5/16 Outlet Header: 14-5/8×1-5/16 Tran Oil Cooler: NONE</p> <p>Inlet Conn: 1-11/32 Outlet Conn: 1-11/32 Eng Oil Cooler: 7-7/8(Concentric)</p> <p>OEM: 16400-21160 / 16400-21180</p>	<p>02-05 Camry 6cyl (26mm) LT0551 DPI:2434</p>  <p>Core Size: 15-3/4×29×1</p> <p>Inlet Header: 29-3/4×1-7/8 Outlet Header: 29-3/4×1-7/8 Tran Oil Cooler: NONE</p> <p>Inlet Conn: 1-9/16 Outlet Conn: 1-9/16 Eng Oil Cooler: 14-3/4(Concentric)</p> <p>OEM: 16400-0A240</p>
<p>02-05 Camry 4cyl(16mm) LT0552 DPI:2435</p>  <p>Core Size: 15-3/4×29×5/8</p> <p>Inlet Header: 29-3/4×1-7/8 Outlet Header: 29-3/4×1-7/8 Tran Oil Cooler: NONE</p> <p>Inlet Conn: 1-9/16 Outlet Conn: 1-9/16 Eng Oil Cooler: 11-3/4(Concentric)</p> <p>OEM: 16400-20270 NISSENS: 64633</p>	<p>02-05 Camry 4cyl(16mm) LT0554 DPI:2437(16)</p>  <p>Core Size: 15-3/4×29×5/8</p> <p>Inlet Header: 29-3/4×1-1/4 Outlet Header: 29-3/4×1-7/8 Tran Oil Cooler: NONE</p> <p>Inlet Conn: 1-3/8 Outlet Conn: 1-3/8 Eng Oil Cooler: 14-3/4(Concentric)</p> <p>NISSENS: 646351</p>

TOYOTA

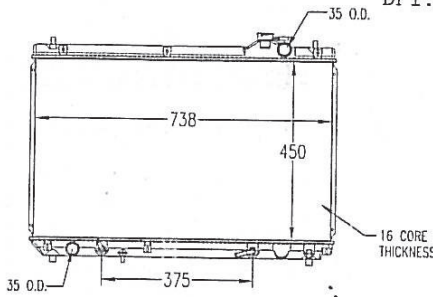
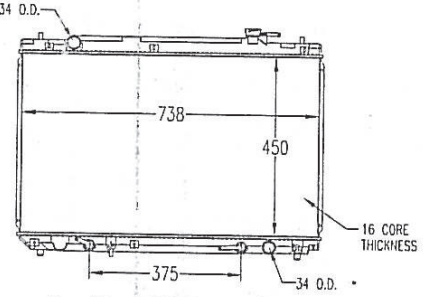
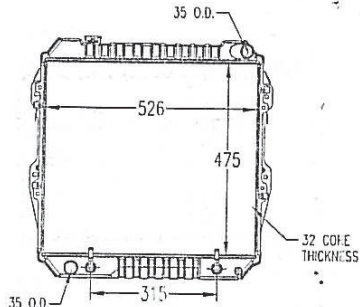
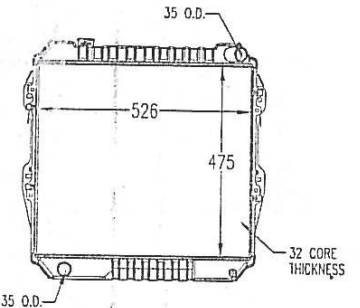
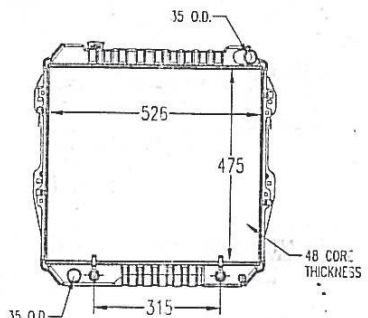
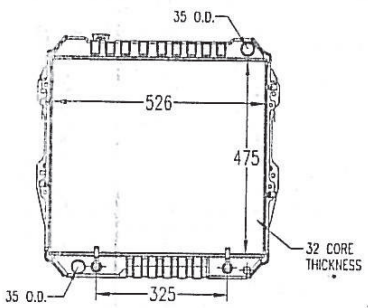
<p>01-03 Highlander 3.0L 6cyl LT0565 DPI:2452</p>  <p>Core Size: 17-3/4×29×5/8 Inlet Header: 29-3/4×1-7/8 Outlet Header: 29-3/4×1-7/8 Tran Oil Cooler: NONE Inlet Conn: 1-3/8 Outlet Conn: 1-3/8 Eng Oil Cooler: 14-3/4(Concentric)</p> <p>OEM: 16400-20180 / 16400-20230</p>	<p>01-06 01-05 Highlander 2.4L 4cyl LT0566 DPI:2453</p>  <p>Core Size: 17-3/4×29×5/8 Inlet Header: 29-3/4×1-7/8 Outlet Header: 29-3/4×1-7/8 Tran Oil Cooler: NONE Inlet Conn: 1-9/16 Outlet Conn: 1-9/16 Eng Oil Cooler: 14-3/4(Concentric)</p> <p>OEM: 16400-28220 / 16400-28250</p>
<p>88- 95 Hilux/4 Runner/Pickup V6 3.0 LT0006 DPI:50</p>  <p>Core Size: 18-11/16×20-3/4×1-1/4 Inlet Header: 20-5/8×2-9/16 Outlet Header: 20-5/8×2-9/16 Tran Oil Cooler: NONE Inlet Conn: 1-3/8 Outlet Conn: 1-3/8 Eng Oil Cooler: 12-7/16(Concentric)</p> <p>OEM: 16400-65041 / 16400-65040</p>	<p>88- 95 Hilux/4 Runner/Pickup V6 3.0 LT0670 DPI:50MT</p>  <p>Core Size: 18-11/16×20-3/4×1-1/4 Inlet Header: 20-5/8×2-9/16 Outlet Header: 20-5/8×2-9/16 Tran Oil Cooler: NONE Inlet Conn: 1-3/8 Outlet Conn: 1-3/8 Eng Oil Cooler: NONE</p> <p>OEM: 16400-65040 / 16400-65100 / 16400-65041</p>
<p>88- 95 Hilux/4 Runner/Pickup V6 3.0 LT0671 DPI:50</p>  <p>Core Size: 18-11/16×20-3/4×1-7/8 Inlet Header: 20-5/8×2-9/16 Outlet Header: 20-5/8×2-9/16 Tran Oil Cooler: NONE Inlet Conn: 1-3/8 Outlet Conn: 1-3/8 Eng Oil Cooler: 12-7/16(Concentric)</p> <p>OEM: 16400-65041 / 16400-65040</p>	<p>88- 95 Hilux/4 Runner/Pickup V6 3.0 LT0672 DPI:50-1</p>  <p>Core Size: 18-11/16×20-3/4×1-1/4 Inlet Header: 20-5/8×2-9/16 Outlet Header: 20-5/8×2-9/16 Tran Oil Cooler: NONE Inlet Conn: 1-3/8 Outlet Conn: 1-3/8 Eng Oil Cooler: 12-13/16(Concentric)</p> <p>OEM: 16400-65041 / 16400-65040</p>
<p>Notes: 1 Row, Plastic Tanks/Aluminum Core</p>	<p>Notes: 1 Row, Plastic Tanks/Aluminum Core</p>

TOYOTA

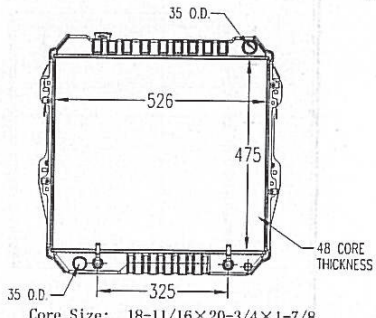
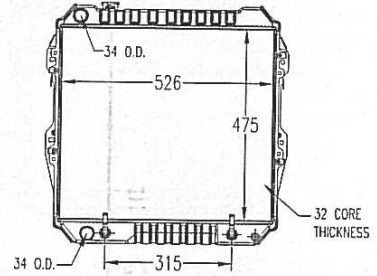
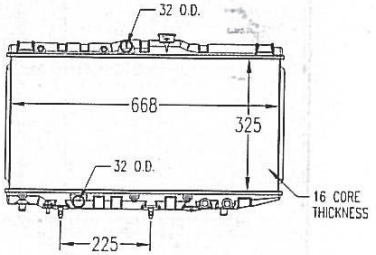
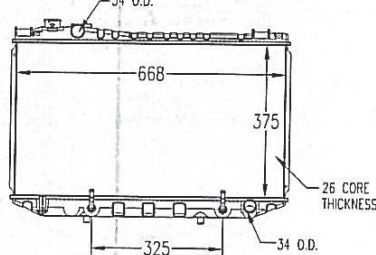
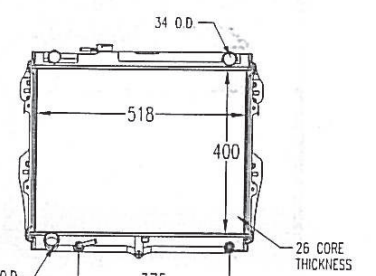
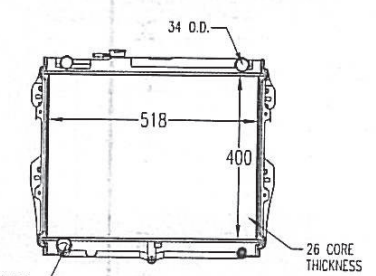
<p>88- 95 Hilux/4 Runner/Pickup V6 3.0 LT0673 DPI:50-1</p>  <p>Core Size: 18-11/16×20-3/4×1-7/8</p> <p>Inlet Header: 20-5/6×2-9/16 Outlet Header: 20-5/6×2-9/16 Tran Oil Cooler: NONE</p> <p>Inlet Conn: 1-3/8 Outlet Conn: 1-3/8 Eng Oil Cooler: 12-13/16 (Concentric)</p>	<p>88- 95 Hilux/4 Runner/Pickup V6 3.0 LT0674 DPI:50A</p>  <p>Core Size: 18-11/16×20-3/4×1-7/8</p> <p>Inlet Header: 20-5/6×2-9/16 Outlet Header: 20-5/6×2-9/16 Tran Oil Cooler: NONE</p> <p>Inlet Conn: 1-9/16 Outlet Conn: 1-9/16 Eng Oil Cooler: 12-7/16 (Concentric)</p> <p>Notes:</p>
<p>88-92 Corolla , GEO Prizm LT0042 DPI:537</p>  <p>Core Size: 12-13/16×26-5/16×5/8</p> <p>Inlet Header: 27×1-9/16 Outlet Header: 27×1-15/16 Tran Oil Cooler: NONE</p> <p>Inlet Conn: 1-1/4 Outlet Conn: 1-1/4 Eng Oil Cooler: 8-7/8 (Concentric)</p> <p>OEM: 16400-11210 / 16400-16200</p>	<p>85-88 Cressida LT0076 DPI:939</p>  <p>Core Size: 14-3/4×26-5/16×1</p> <p>Inlet Header: 27×2 Outlet Header: 27×2 Tran Oil Cooler: NONE</p> <p>Inlet Conn: 1-9/16 Outlet Conn: 1-9/16 Eng Oil Cooler: 12-13/16 (Concentric)</p> <p>OEM: 16400-41380</p>
<p>84- Hilux/4 Runner/Pickup LT0079 DPI:945</p>  <p>Core Size: 15-3/4×20-3/8×1</p> <p>Inlet Header: 21-7/16×2-1/6 Outlet Header: 21-7/16×2-1/6 Tran Oil Cooler: NONE</p> <p>Inlet Conn: 1-9/16 Outlet Conn: 1-9/16 Eng Oil Cooler: 14-3/4 (Concentric)</p> <p>OEM: 16400-35390 / 16400-35540</p>	<p>84- Hilux/4 Runner/Pickup LT0080 DPI:945MT</p>  <p>Core Size: 15-3/4×20-3/8×1</p> <p>Inlet Header: 21-7/16×2-1/6 Outlet Header: 21-7/16×2-1/6 Tran Oil Cooler: NONE</p> <p>Inlet Conn: 1-9/16 Outlet Conn: 1-9/16 Eng Oil Cooler: NONE</p> <p>OEM: 16400-35350 / 16400-71080</p>

TOYOTA

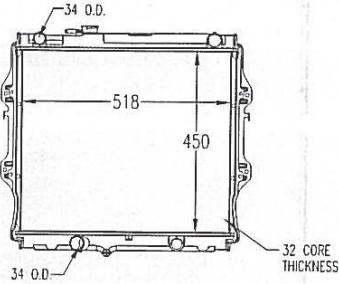
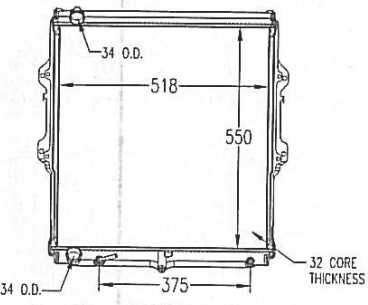
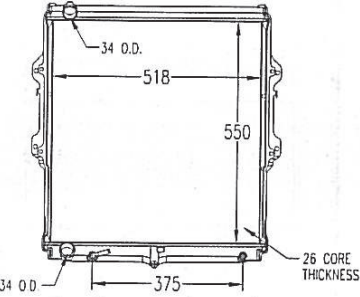
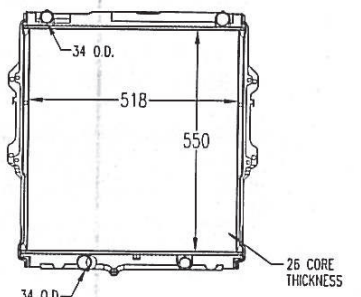
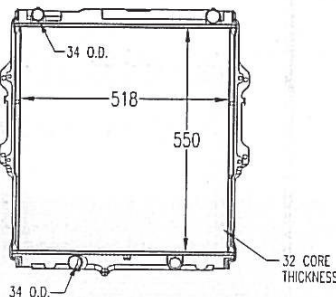
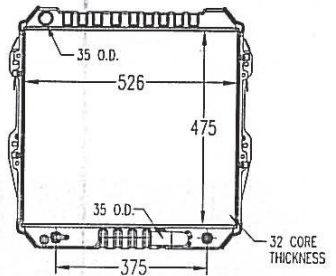
<p>LT2001</p> <p style="text-align: right;">DPI:</p>  <p>Core Size: 17-11/16×20-3/8×1-1/4</p> <p>Inlet Header: 21-7/16×2-1/6 Outlet Header: 21-7/16×2-1/6 Tran Oil Cooler: NONE</p> <p>Inlet Conn: 1-9/16 Outlet Conn: 1-9/16 Eng Oil Cooler: NONE</p>	<p>LT2002</p> <p style="text-align: right;">DPI:</p>  <p>Core Size: 21-5/8×20-3/8×1-1/4</p> <p>Inlet Header: 21-7/16×2-1/6 Outlet Header: 21-7/16×2-1/6 Tran Oil Cooler: NONE</p> <p>Inlet Conn: 1-9/16 Outlet Conn: 1-9/16 Eng Oil Cooler: 14-3/4 (Concentric)</p>
<p>OEM: 16400-5B630</p>	
<p>LT2003</p> <p style="text-align: right;">DPI:</p>  <p>Core Size: 21-5/8×20-3/8×1</p> <p>Inlet Header: 21-7/16×2-1/6 Outlet Header: 21-7/16×2-1/6 Tran Oil Cooler: NONE</p> <p>Inlet Conn: 1-9/16 Outlet Conn: 1-9/16 Eng Oil Cooler: 14-3/4 (Concentric)</p>	<p>LT2004</p> <p style="text-align: right;">DPI:</p>  <p>Core Size: 21-5/8×20-3/8×1</p> <p>Inlet Header: 21-7/16×2-1/6 Outlet Header: 21-7/16×2-1/6 Tran Oil Cooler: NONE</p> <p>Inlet Conn: 1-9/16 Outlet Conn: 1-9/16 Eng Oil Cooler: NONE</p>
<p>LT2005</p> <p style="text-align: right;">DPI:</p>  <p>Core Size: 21-5/8×20-3/8×1-1/4</p> <p>Inlet Header: 21-7/16×2-1/6 Outlet Header: 21-7/16×2-1/6 Tran Oil Cooler: NONE</p> <p>Inlet Conn: 1-9/16 Outlet Conn: 1-9/16 Eng Oil Cooler: NONE</p>	<p>LT2020</p> <p style="text-align: right;">DPI:</p>  <p>Core Size: 18-11/16×20-11/16×1-1/4</p> <p>Inlet Header: 20-5/6×2-9/16 Outlet Header: 20-5/6×2-9/16 Tran Oil Cooler: NONE</p> <p>Inlet Conn: 1-3/8 Outlet Conn: 1-3/8 Eng Oil Cooler: 14-3/4 (Concentric)</p>

TOYOTA

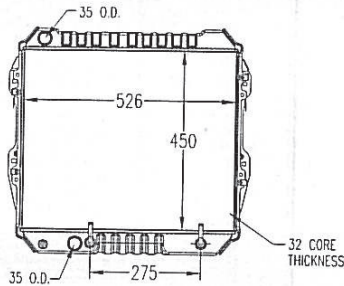
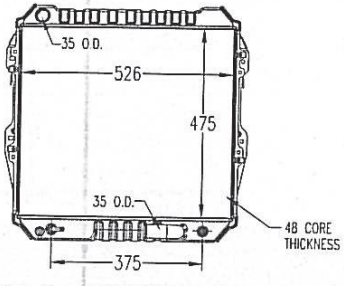
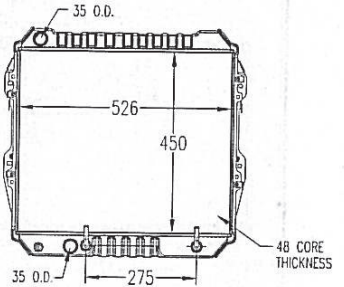
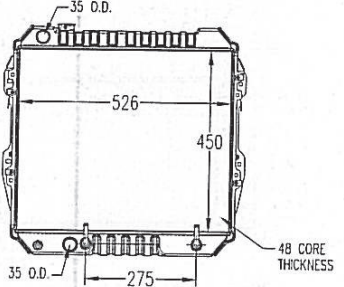
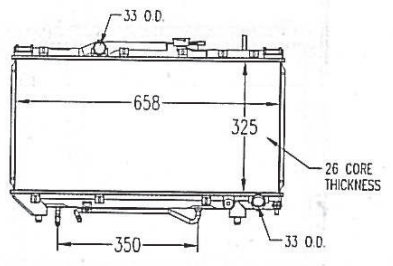
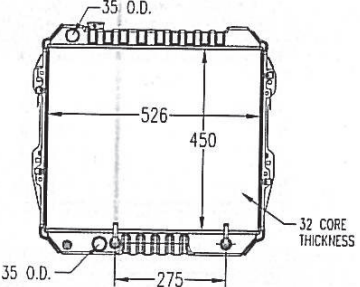
<p>LT2021</p> <p style="text-align: right;">DPI:</p>  <p>Core Size: 17-11/16×20-11/16×1-1/4</p> <table border="0"> <tr> <td>Inlet Header: 20-5/6×2-9/16</td> <td>Inlet Conn: 1-3/8</td> </tr> <tr> <td>Outlet Header: 20-5/6×2-9/16</td> <td>Outlet Conn: 1-3/8</td> </tr> <tr> <td>Tran Oil Cooler: NONE</td> <td>Eng Oil Cooler: 10-5/6(Concentric)</td> </tr> </table>	Inlet Header: 20-5/6×2-9/16	Inlet Conn: 1-3/8	Outlet Header: 20-5/6×2-9/16	Outlet Conn: 1-3/8	Tran Oil Cooler: NONE	Eng Oil Cooler: 10-5/6(Concentric)	<p>LT2024</p> <p style="text-align: right;">DPI:</p>  <p>Core Size: 18-11/16×20-11/16×1-7/8</p> <table border="0"> <tr> <td>Inlet Header: 20-5/6×2-9/16</td> <td>Inlet Conn: 1-3/8</td> </tr> <tr> <td>Outlet Header: 20-5/6×2-9/16</td> <td>Outlet Conn: 1-3/8</td> </tr> <tr> <td>Tran Oil Cooler: NONE</td> <td>Eng Oil Cooler: 14-3/4(Concentric)</td> </tr> </table>	Inlet Header: 20-5/6×2-9/16	Inlet Conn: 1-3/8	Outlet Header: 20-5/6×2-9/16	Outlet Conn: 1-3/8	Tran Oil Cooler: NONE	Eng Oil Cooler: 14-3/4(Concentric)
Inlet Header: 20-5/6×2-9/16	Inlet Conn: 1-3/8												
Outlet Header: 20-5/6×2-9/16	Outlet Conn: 1-3/8												
Tran Oil Cooler: NONE	Eng Oil Cooler: 10-5/6(Concentric)												
Inlet Header: 20-5/6×2-9/16	Inlet Conn: 1-3/8												
Outlet Header: 20-5/6×2-9/16	Outlet Conn: 1-3/8												
Tran Oil Cooler: NONE	Eng Oil Cooler: 14-3/4(Concentric)												
<p>LT2025</p> <p style="text-align: right;">DPI:</p>  <p>Core Size: 17-11/16×20-11/16×1-7/8</p> <table border="0"> <tr> <td>Inlet Header: 20-5/6×2-9/16</td> <td>Inlet Conn: 1-3/8</td> </tr> <tr> <td>Outlet Header: 20-5/6×2-9/16</td> <td>Outlet Conn: 1-3/8</td> </tr> <tr> <td>Tran Oil Cooler: NONE</td> <td>Eng Oil Cooler: 10-5/6(Concentric)</td> </tr> </table>	Inlet Header: 20-5/6×2-9/16	Inlet Conn: 1-3/8	Outlet Header: 20-5/6×2-9/16	Outlet Conn: 1-3/8	Tran Oil Cooler: NONE	Eng Oil Cooler: 10-5/6(Concentric)	<p>LT2026</p> <p style="text-align: right;">DPI:</p>  <p>Core Size: 17-11/16×20-11/16×1-7/8</p> <table border="0"> <tr> <td>Inlet Header: 20-5/6×2-9/16</td> <td>Inlet Conn: 1-3/8</td> </tr> <tr> <td>Outlet Header: 20-5/6×2-9/16</td> <td>Outlet Conn: 1-3/8</td> </tr> <tr> <td>Tran Oil Cooler: NONE</td> <td>Eng Oil Cooler: 10-5/6(Concentric)</td> </tr> </table>	Inlet Header: 20-5/6×2-9/16	Inlet Conn: 1-3/8	Outlet Header: 20-5/6×2-9/16	Outlet Conn: 1-3/8	Tran Oil Cooler: NONE	Eng Oil Cooler: 10-5/6(Concentric)
Inlet Header: 20-5/6×2-9/16	Inlet Conn: 1-3/8												
Outlet Header: 20-5/6×2-9/16	Outlet Conn: 1-3/8												
Tran Oil Cooler: NONE	Eng Oil Cooler: 10-5/6(Concentric)												
Inlet Header: 20-5/6×2-9/16	Inlet Conn: 1-3/8												
Outlet Header: 20-5/6×2-9/16	Outlet Conn: 1-3/8												
Tran Oil Cooler: NONE	Eng Oil Cooler: 10-5/6(Concentric)												
<p>LT2033</p> <p style="text-align: right;">DPI:</p>  <p>Core Size: 12-13/16×26×1</p> <table border="0"> <tr> <td>Inlet Header: 26-11/16×1-7/8</td> <td>Inlet Conn: 1-5/16</td> </tr> <tr> <td>Outlet Header: 26-11/16×1-7/8</td> <td>Outlet Conn: 1-5/16</td> </tr> <tr> <td>Tran Oil Cooler: NONE</td> <td>Eng Oil Cooler: 13-3/4(Concentric)</td> </tr> </table>	Inlet Header: 26-11/16×1-7/8	Inlet Conn: 1-5/16	Outlet Header: 26-11/16×1-7/8	Outlet Conn: 1-5/16	Tran Oil Cooler: NONE	Eng Oil Cooler: 13-3/4(Concentric)	<p>LT2022</p> <p style="text-align: right;">DPI:</p>  <p>Core Size: 17-11/16×20-11/16×1-1/4</p> <table border="0"> <tr> <td>Inlet Header: 20-5/6×2-9/16</td> <td>Inlet Conn: 1-3/8</td> </tr> <tr> <td>Outlet Header: 20-5/6×2-9/16</td> <td>Outlet Conn: 1-3/8</td> </tr> <tr> <td>Tran Oil Cooler: NONE</td> <td>Eng Oil Cooler: 10-5/6(Concentric)</td> </tr> </table>	Inlet Header: 20-5/6×2-9/16	Inlet Conn: 1-3/8	Outlet Header: 20-5/6×2-9/16	Outlet Conn: 1-3/8	Tran Oil Cooler: NONE	Eng Oil Cooler: 10-5/6(Concentric)
Inlet Header: 26-11/16×1-7/8	Inlet Conn: 1-5/16												
Outlet Header: 26-11/16×1-7/8	Outlet Conn: 1-5/16												
Tran Oil Cooler: NONE	Eng Oil Cooler: 13-3/4(Concentric)												
Inlet Header: 20-5/6×2-9/16	Inlet Conn: 1-3/8												
Outlet Header: 20-5/6×2-9/16	Outlet Conn: 1-3/8												
Tran Oil Cooler: NONE	Eng Oil Cooler: 10-5/6(Concentric)												

TOYOTA

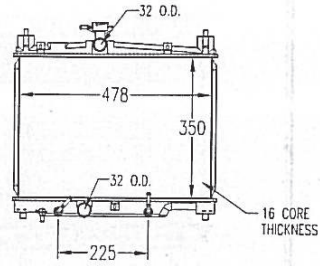
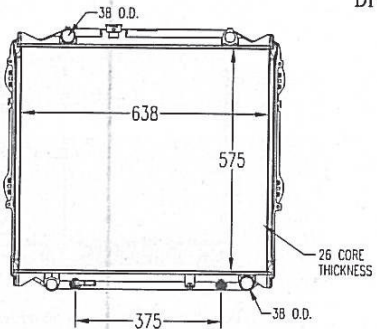
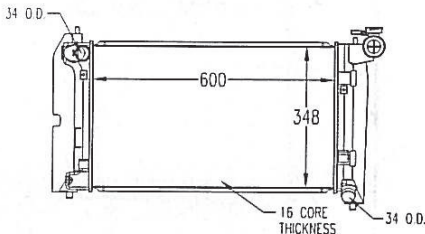
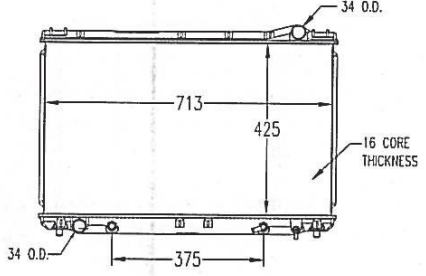
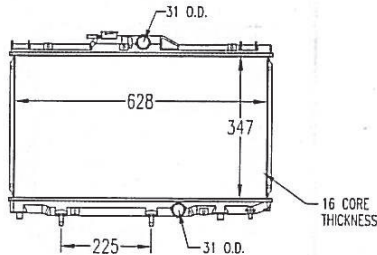
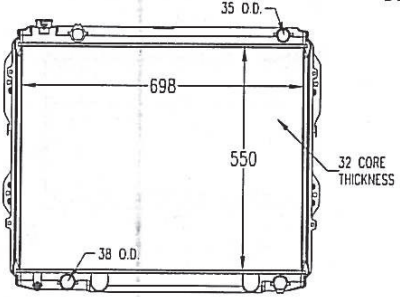
<p>LT2036</p> <p style="text-align: right;">DPI:</p>  <p>Core Size: 13-3/4×18-5/6×5/8</p> <p>Inlet Header: 19-7/8×1-5/16 Outlet Header: 19-7/8×1-9/16 Tran Oil Cooler: NONE</p> <p>Inlet Conn: 1-1/4 Outlet Conn: 1-1/4 Eng Oil Cooler: 8-7/8 (Concentric)</p> <p>OEM: 16400-23110 / 16400-23090</p>	<p>LT2035</p> <p style="text-align: right;">DPI:</p>  <p>Core Size: 22-5/8×25-1/8×1</p> <p>Inlet Header: 26×1-7/8 Outlet Header: 26×1-7/8 Tran Oil Cooler: NONE</p> <p>Inlet Conn: 1-1/2 Outlet Conn: 1-1/2 Eng Oil Cooler: 14-3/4 (Concentric)</p>
<p>03-05 Corolla</p>	
<p>LT0549</p> <p style="text-align: right;">DPI: 2432</p>  <p>Core Size: 23-5/8×13-5/7×5/8</p> <p>Inlet Header: 14-2/3×1-2/7 Outlet Header: 14-2/3×1-2/7 Tran Oil Cooler: NONE</p> <p>Inlet Conn: 1-11/32 Outlet Conn: 1-11/32 Eng Oil Cooler: NONE</p> <p>OEM: 16600-21300 / 16400-21140</p>	<p>LT0675</p> <p style="text-align: right;">DPI: 1746</p>  <p>Core Size: 16-3/4×28-1/16×5/8</p> <p>Inlet Header: 29×1-7/8 Outlet Header: 29×1-7/8 Tran Oil Cooler: NONE</p> <p>Inlet Conn: 1-5/16 Outlet Conn: 1-5/16 Eng Oil Cooler: 14-3/4 (Concentric)</p> <p>OEM: 16400-0A0303 / 16400-0A031 / 16400-0A032 / 16400-0A020</p>
<p>00-04 Tundra</p>	
<p>LT0427</p> <p style="text-align: right;">DPI: 2219</p>  <p>Core Size: 13-11/16×24-3/4×5/8</p> <p>Inlet Header: 25-3/4×1-5/8 Outlet Header: 25-3/4×1-5/8 Tran Oil Cooler: NONE</p> <p>Inlet Conn: 1-1/4 Outlet Conn: 1-1/4 Eng Oil Cooler: 8-7/8 (Concentric)</p> <p>OEM: 16400-0D040</p>	<p>LT0477</p> <p style="text-align: right;">DPI: 2322</p>  <p>Core Size: 21-5/8×27-1/2×1-1/4</p> <p>Inlet Header: 2-3/16×28-3/16 Outlet Header: 2-3/16×28-3/16 Tran Oil Cooler: NONE</p> <p>Inlet Conn: 1-3/8 Outlet Conn: 1-1/2 Eng Oil Cooler: NONE</p> <p>OEM: 16400-07070</p>

TOYOTA

87-91 Camry, Lexus ES 200		93-97 Corolla, GEO Prizm	
LT0002 DPI:21	<p>Core Size: 12-13/16x26-11/16x1</p> <p>Inlet Header: 27-13/16x1-15/16 Inlet Conn: 1-5/16 Outlet Header: 27-13/16x1-15/16 Outlet Conn: 1-1/4 Tran Oil Cooler: NONE Eng Oil Cooler: 10-13/16(Concentric)</p> <p>OEM: 16400-62020</p>	LT0189 DPI:1436	<p>Core Size: 13-3/4x25-1/8x5/8</p> <p>Inlet Header: 26x1-5/16 Inlet Conn: 1-1/4 Outlet Header: 26x1-9/16 Outlet Conn: 1-1/4 Tran Oil Cooler: NONE Eng Oil Cooler: NONE</p> <p>OEM: 16400-15450 /-15451</p>
96-98 RAV4		99-00 Lexus RX 300 Standard Duty	
LT0329 DPI:1860	<p>Core Size: 13-3/4x27-3/16x1</p> <p>Inlet Header: 28-5/16x1-7/8 Inlet Conn: 1-1/4 Outlet Header: 28-5/16x1-7/8 Outlet Conn: 1-1/4 Tran Oil Cooler: NONE Eng Oil Cooler: NONE</p> <p>OEM: 16400-7A110 / 16400-7A111</p>	LT0445 DPI:2271	<p>Core Size: 17-3/4x29-1/16x5/8</p> <p>Inlet Header: 29-3/4x1-7/8 Inlet Conn: 1-3/8 Outlet Header: 29-3/4x1-7/8 Outlet Conn: 1-3/8 Tran Oil Cooler: NONE Eng Oil Cooler: 14-3/4(Concentric)</p> <p>OEM: 16400-20120/16400-20180</p>
99-00 Lexus RX 300 Heavy Duty			
LT0446 DPI:2272	<p>Core Size: 17-5/4x29-1/16x1</p> <p>Inlet Header: 29-3/4x1-7/8 Inlet Conn: 1-3/8 Outlet Header: 29-3/4x1-7/8 Outlet Conn: 1-3/8 Tran Oil Cooler: NONE Eng Oil Cooler: 14-3/4(Concentric)</p> <p>OEM: 16400-20140</p>	LT0460 DPI:2299	<p>Core Size: 15-3/4x29-1/16x5/8</p> <p>Inlet Header: 29-3/4xi-7/8 Inlet Conn: 1-3/8 Outlet Header: 29-3/4x1-7/8 Outlet Conn: 1-3/8 Tran Oil Cooler: NONE Eng Oil Cooler: 14-3/4(Concentric)</p>

TOYOTA

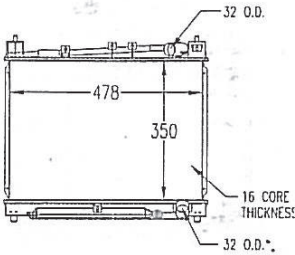
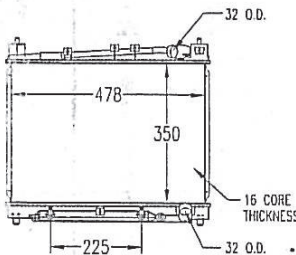
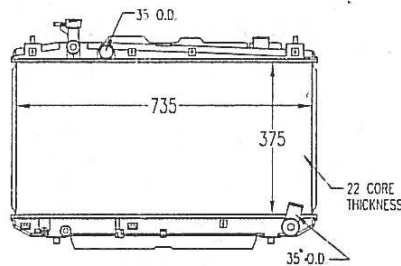
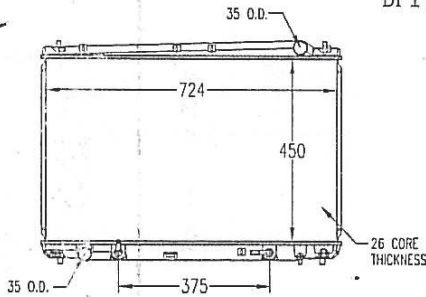
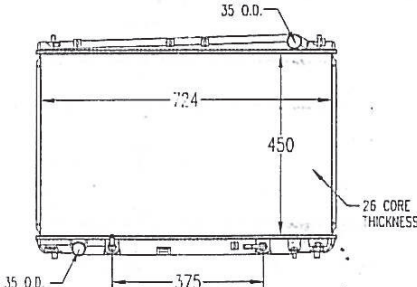
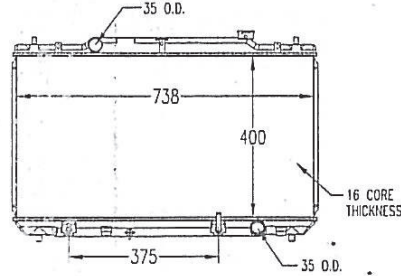
<p>00-05 Echo/Vitz</p> <p>LT0465 DPI:2304</p>  <p>Core Size: 13-3/4×18-5/6×5/8</p> <p>Inlet Header: 19-7/8×1-5/16 Inlet Conn: 1-1/4 Outlet Header: 19-7/8×1-9/16 Outlet Conn: 1-1/4 Tran Oil Cooler: NONE Eng Oil Cooler: NONE</p> <p>OEM: 16400-21060/16400-21080</p>	<p>00-05 Echo/Vitz</p> <p>LT0466 DPI:2305</p>  <p>Core Size: 13-3/4×18-5/6×5/8</p> <p>Inlet Header: 19-7/8×1-5/16 Inlet Conn: 1-1/4 Outlet Header: 19-7/8×1-9/16 Outlet Conn: 1-1/4 Tran Oil Cooler: NONE Eng Oil Cooler: 8-7/8(Concentric)</p> <p>OEM: 16400-21070/16400-21090 NISSENS: 64799A</p>
<p>01-03 RAV4</p> <p>LT0534 DPI:2404</p>  <p>Core Size: 14-3/4×29×7/8</p> <p>Inlet Header: 30×1-9/16 Inlet Conn: 1-3/8 Outlet Header: 30×1-9/16 Outlet Conn: 1-3/8 Tran Oil Cooler: NONE Eng Oil Cooler: NONE</p> <p>OEM: 16400-28130/16400-28170</p>	<p>98-00 Sienna</p> <p>LT0547 DPI:2427</p>  <p>Core Size: 17-3/4×28-1/2×1</p> <p>Inlet Header: 29-3/8×2 Inlet Conn: 1-3/8 Outlet Header: 29-3/8×2 Outlet Conn: 1-3/8 Tran Oil Cooler: NONE Eng Oil Cooler: 14-3/4(Concentric)</p> <p>OEM: 16400-0A071</p>
<p>98-00 Sienna</p> <p>LT0402 DPI:2153</p>  <p>Core Size: 17-3/4×28-1/2×1</p> <p>Inlet Header: 29-3/8×2 Inlet Conn: 1-3/8 Outlet Header: 29-3/8×2 Outlet Conn: 1-3/8 Tran Oil Cooler: NONE Eng Oil Cooler: 14-3/4(Concentric)</p> <p>OEM: 16400-0A071</p>	<p>02-03 Camry/Solara 2.1 4cyl</p> <p>LT0609 DPI:2623</p>  <p>Core Size: 15-3/4×29-1/16×5/8</p> <p>Inlet Header: 29-3/4×1-5/16 Inlet Conn: 1-3/8 Outlet Header: 29-3/4×1-7/8 Outlet Conn: 1-3/8 Tran Oil Cooler: NONE Eng Oil Cooler: 14-3/4(Concentric)</p> <p>OEM: 16400-0H050</p>

TOYOTA

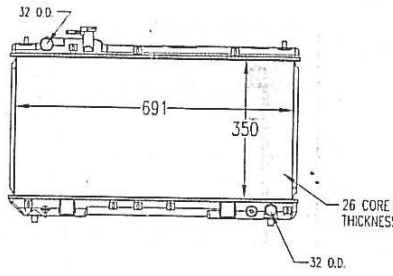
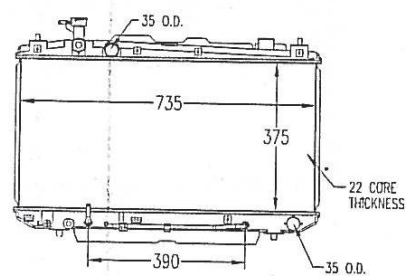
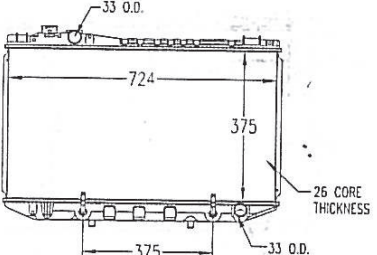
98-00 RAV 4		01-03 RAV 4	
<p>LT0456</p> <p>DPI:2293</p>  <p>Core Size: 13-3/4×27-3/16×1</p> <p>Inlet Header: 28-5/16×1-7/8 Outlet Header: 28-5/16×1-7/8 Tran Oil Cooler: NONE</p> <p>Inlet Conn: 1-1/4 Outlet Conn: 1-1/4 Eng Oil Cooler: NONE</p> <p>OEM: 16400-7A490</p>	<p>LT0676</p> <p>DPI:2411</p>  <p>Core Size: 14-3/4×29×7/8</p> <p>Inlet Header: 30×1-9/16 Outlet Header: 30×1-9/16 Tran Oil Cooler: NONE</p> <p>Inlet Conn: 1-3/8 Outlet Conn: 1-3/8 Eng Oil Cooler: 15-3/8(Concentric)</p> <p>OEM: 16400-22130/16400-2B140</p>		
<p>89-92 Cressida</p> <p>LT0019</p> <p>DPI:178</p>  <p>Core Size: 14-3/4×28-1/2×1</p> <p>Inlet Header: 28-5/8×1-15/16 Outlet Header: 28-5/8×1-15/16 Tran Oil Cooler: NONE</p> <p>Inlet Conn: 1-5/16 Outlet Conn: 1-5/16 Eng Oil Cooler: 14-3/4(Concentric)</p> <p>OEM: 16400-70341</p>			